



# LOJER KRANKENHAUSBETT SCANAFIA X ICU E-480, TRENDELENBURG ELEKTR. ANLEITUNG

Art.-Nr.  65520 · Kategorie:  Krankenhausbetten

**LOJER<sup>®</sup>**

*For easy care*



## **ScanAfia X TK, S and ICU Hospital bed**

### **Operating manual**

**Version 1.5**

**26.04.2019**

## Warranty period

The product's warranty period is defined in the sales contract documents. The warranty applies to material and manufacturing defects. Unless otherwise agreed, the warranty period is 2 years for components excluding the steel frame structure, which has a warranty period of 10 years. Wear parts (such as curtains, batteries, strings/wire ropes) have a warranty period of 1 year.

The warranty period begins on the day the product is dispatched from the factory. Warranty claims shall be presented to Lojer Service within 7 days from discovering the defect, preferably in writing.

The recipient shall inspect the delivery on arrival and notify the transporter (driver) immediately of any external damages. The representative of the transportation company will note and claim the damages. If the damages to the delivery are not noticed immediately, they must be notified as soon as possible to Lojer. Take a photo of the damaged package and keep the package until the matter has been processed.

## Scope and payment of compensations under warranty

Warranty applies to emerging material and manufacturing defects claimed within the warranty period. The warranty does not cover defects caused by use other than that consistent with the operating and service instructions. The warranty is limited to rectifying the characteristics and status of the product so that they correspond to those of the original product before the detection of the defect. For this reason it is sufficient that the product meets the requirements set for the original product by Lojer according to the technical specifications. The warranty service is either repair or replacement based on Lojer's choice and within the warranty instructions. In the case of material or manufacturing defect of components, the warranty reimburses components that are new or as good as new. If repair of the product is not possible, it may be replaced by a similar or operationally equal product. In all cases, the value of the compensation under warranty is limited to the value of the defective product.

## Warranty procedure

Contact Lojer Service and give your contact information, the name and serial number of the product and description of the problem (provide photos/video is needed). Our helpdesk assist you to recognise defects and defective operations. In many cases they are able to locate the defect already during the phone call. If the defect cannot be rectified based on the conversation with the service personnel, the customer is informed of how to rectify the defect in one of the following ways:

1) **The customer is sent a spare part which the customer replaces.** If, based on the manufacturer's estimate, replacing the part and/or repairing the defect requires a trained service technician, Lojer will arrange for the repair within approximately two weeks. If the repair of the defect is required immediately, Lojer is entitled to invoice travel expenses. Even in such a case, the repair work

is under warranty. The defective components removed from the product under the warranty become the property of Lojer and the customer is obligated to store them if needed. If these components cannot be delivered to Lojer at request, Lojer is entitled to send an invoice for them according to the spare part price list.

**2) The customer sends the product to a given Lojer service shop for repair.** In this case, the customer is liable for shipping the product according to the instructions given by Lojer. In the case of repair under warranty, Lojer pays the cost of the required materials, spare parts and repair work as well as the cost of shipping the device back to the customer.

It is not always possible to determine the application of warranty over the phone or on the spot. In this case, the defective component may be sent to a third party for inspection, for example. If the inspection reveals that the warranty is not applied to the defect, Lojer is entitled to charge for the component and for replacing it. The remaining warranty period of the repaired device applies to the original Lojer components installed during repair under warranty.

### **Excluded from warranty**

The warranty does not cover irrelevant defects/deviations in the structure of the product when they are insignificant to the operation of the device. Neither does the warranty cover fault diagnostics and repair of malfunctions resulting from the following:

- The customer or third party has used the device inappropriately or against the operating instructions (e.g. manual control is broken, upholstery, wooden components, cables or plugs are damaged)
- Force majeure (fire, lightning, flood, storm etc.)
- Dirt and denting
- Exceptional environmental impact (overvoltage, magnetic fields etc.).

### **Warranty is void**

- If detergents other than those indicated in the operating instructions are used for cleaning the product, or if the product is exposed to substances other than those indicated in the instructions.
- If Lojer products are equipped with parts or components or they are used with parts or components not approved by Lojer for the said product.
- If a person other than one trained in healthcare instrument service performs maintenance or repair which is not expressly assigned to the said person.
- If a person not authorised by Lojer makes modifications to the device.
- If the scheduled servicing is not verifiably performed.

## Content

<b>1</b>	<b>ScanAfia X hospital bed</b> .....	<b>1</b>
<b>2</b>	<b>ScanAfia X hospital bed components</b> .....	<b>2</b>
2.1	Accessories.....	3
2.2	Removable components.....	4
<b>3</b>	<b>Acceptance inspection and storage</b> .....	<b>5</b>
<b>4</b>	<b>Safety instructions</b> .....	<b>6</b>
4.1	Safe use of power cable .....	8
4.2	Symbols used in the hospital bed labels .....	9
4.3	Warning labels used in the hospital bed.....	12
4.4	Warning labels used in hospital bed packaging .....	14
<b>5</b>	<b>Procedures before use</b> .....	<b>15</b>
<b>6</b>	<b>Operating the hospital bed</b> .....	<b>16</b>
6.1	Hand-held controls .....	16
6.2	Locking the wheels.....	19
6.3	Moving and transporting the bed .....	20
6.4	Adjusting bed surface height .....	20
6.5	Adjusting the backrest.....	22
6.6	Emergency lowering of the backrest .....	22
6.7	Adjusting the thigh and leg rest .....	24
6.8	Trendelenburg adjustment .....	24
6.9	Equipotential connection .....	26
6.10	Operating the battery of the hospital bed .....	26
6.11	Removing and fastening the bed surface's plastic boards .....	27
<b>7</b>	<b>Installing and operating accessories</b> .....	<b>28</b>
7.1	Ends (70356KP - 70361KP).....	28
7.2	Long and high side rail (70353KP, 70355KP) .....	30
7.3	Installing the lift support (101910) .....	32
7.4	Operating the dining tray (70253KP, 70257KP) .....	33
7.5	Operating the IV stand (60121, 60122) .....	34
7.6	Operating the nurse's control board (58128).....	35
7.7	Operation of the nurse's locking board (36505).....	38
7.8	Urine bag stand (70379).....	39
7.9	5. Wheel (70363KP) .....	40
7.10	Mattress recommendations .....	41

---

7.11	Battery (AG7) .....	42
7.12	Bed surface extension (70330KP, 70331KP) .....	43
7.13	Trendelenburg handle .....	45
7.14	Emergency lowering of CPR backrest (70342KP, 70345KP) .....	46
7.15	Quick mounting frame (70364KP) .....	48
7.16	Get-up support (70362KP) .....	49
7.17	Stand for the hand-held control (70197KP) .....	50
7.18	Limb restraint handles (70367).....	51
7.19	Cushioned rail guard .....	51
7.20	Rack for crutch and cane (101971) .....	52
<b>8</b>	<b>Cleaning and disinfecting</b> .....	<b>53</b>
8.1	Metal and plastic surfaces .....	53
8.2	Hygiene mattress .....	55
8.3	Wooden surfaces and other materials.....	55
<b>9</b>	<b>Service</b> .....	<b>56</b>
9.1	Maintenance procedures .....	57
9.2	Annual procedures .....	57
9.3	Battery maintenance procedures .....	60
<b>10</b>	<b>Troubleshooting</b> .....	<b>61</b>
<b>11</b>	<b>Specifications</b> .....	<b>63</b>
11.1	Type plate information.....	66
11.2	Relevant standards .....	67
11.3	The bed's applied parts .....	67
<b>12</b>	<b>Recycling</b> .....	<b>68</b>
<b>13</b>	<b>Contact information</b> .....	<b>69</b>
<b>14</b>	<b>References</b> .....	<b>70</b>

# 1 ScanAfia X hospital bed

This document gives operating instruction for the use of the following hospital beds: Lojer ScanAfia X TK-280 / 290, TK-480 / 490, S-280 / 290, S-480 / 490, ICU E- and ICU 480 / 490.

The ScanAfia X series hospital beds are designed to be used by healthcare professionals with patients over the age of 12 and a minimum height of 146cm (categories 1, 2 and 3 of standard EN 60601-2-52: 2010). Models S, ICU E and ICU categories 1, 2 and 3. TK models category 3.

Appropriate environments are:

- intensive care in a hospital
- acute care ward in a hospital, health center or equivalent institution
- wards in hospitals or other equivalent institution offering long-term care.

ScanAfia X TK-, S-, ICU E and ICU hospital beds are available in widths of 80cm or 90cm. The ScanAfia X TK and S models are 2 or 4 function beds and models ScanAfia X ICU E and ICU are 4 function beds. In 2 function beds (TK- and S- 280 / 290), the height of the bed surface and the backrest are adjustable. In 4 function beds (TK-, S-, ICU E and ICU- 480 / 490), in addition, the knee and leg section height and inclination are adjustable.

The models ScanAfia X S, ICU E and ICU also have the Trendelenburg / reverse Trendelenburg functions. Models ICU E and ICU have electrically adjusted Trendelenburg / reverse Trendelenburg functions and the S models are adjusted with a gas spring.

**IMPORTANT!** *Read these instructions carefully before operating the hospital bed.*

**IMPORTANT!** *Following these instructions ensures that the hospital bed is used safely and that the conditions of the warranty are met.*

## 2 ScanAfia X hospital bed components

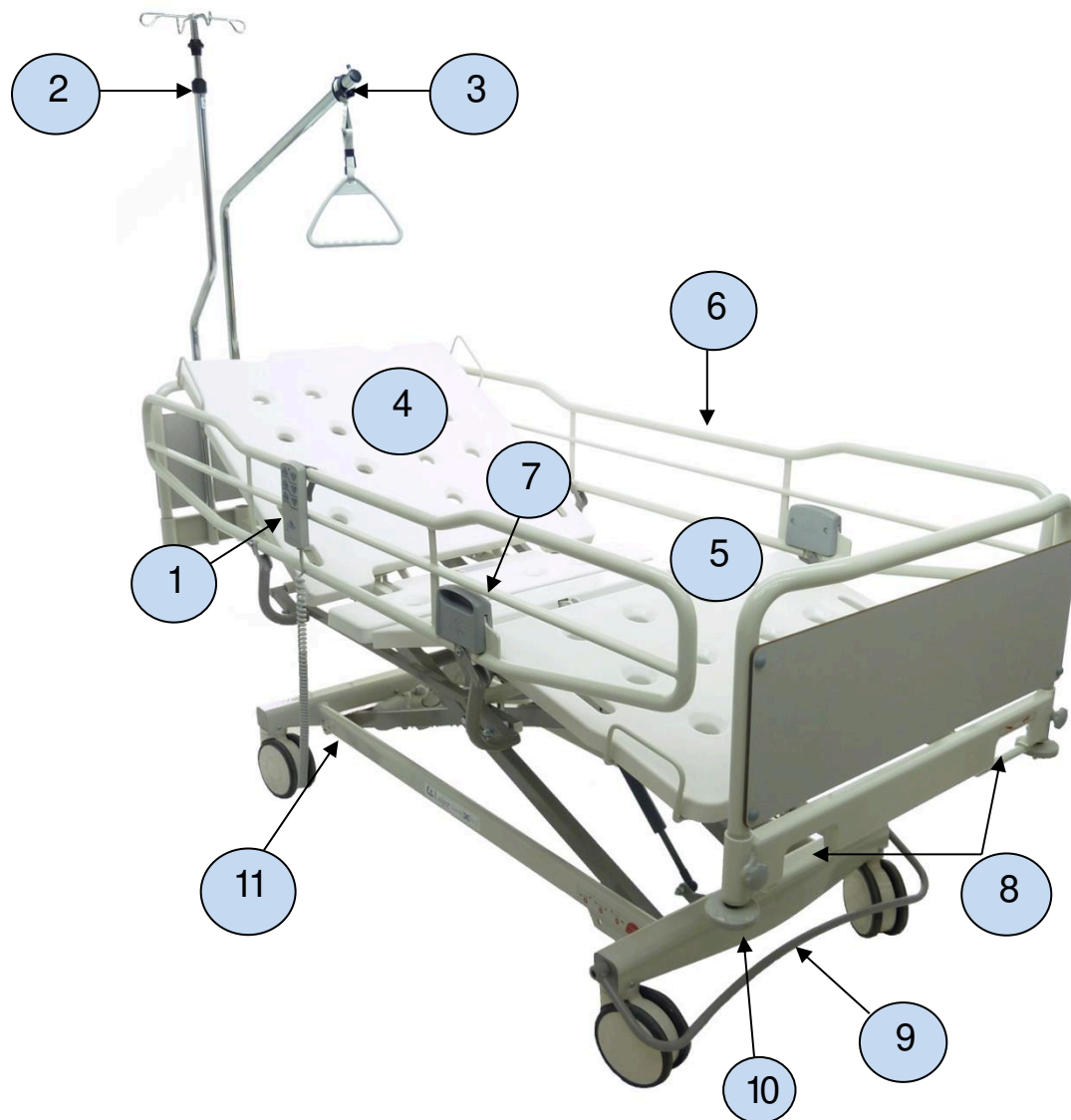

- 1 Hand-held control
- 2 IV stand
- 3 Lift support
- 4 Backrest
- 5 Adjustable thigh and leg rests
- 6 Side rail (long model)
- 7 Side rail adjustment lever
- 8 Trendelenburg levers (S models)
- 9 Brake arc
- 10 Bumper wheel
- 11 Type plate (lower frame, front)

Figure 1. *ScanAfia X hospital bed*



## 2.1 Accessories

**IMPORTANT!** See the model codes of accessories in the table on the following page.

The accessories of the hospital bed include the following:

- Bed ends, normal height, chromium plated or epoxy coated
- High chromium plated ends, with high side rails
- Laminated boards of the ends come in several colors
- Side rails
  - long rails of normal height, chromium plated or epoxy coated
  - long high chromium plated rails
- Wheels, several alternatives:
  - sizes 125mm or 150mm, design, wheels conducting electricity etc.
- Brake pedals, brake arc or brake pedals and brake arc
- Lift support
- IV stand
- Get-up support
- Dining tray
- Nurse's control board
- Nurse's locking board
- Urine bag stand
- Fifth wheel
- Mattress
- Battery system models TK and S (nurse's control board and locking board are standard in beds equipped with a battery system)
- X-ray surface (models S and ICU)
- CPR (models S and ICU)
- Hand-held control stand
- Extension of bed surface (includes Trendelenburg lever in S models) (in ICU models with 150mm design wheels, the extension excludes the bumper wheels) (in beds with 125mm wheels, the extension excludes the bumper wheels at the foot end of bed)
- Cushioned rail guard
- Rack for canes and crutches

<b>Accessory</b>	<b>Model</b>
80cm end	70356KP
90cm end	70357KP
80cm adjustable end	70358KP
90cm adjustable end	70359KP
80cm high end	70360KP
90cm high end	70361KP
Long rails	70353KP
High rails	70355KP
Lift support	101901
IV stand (straight)	60121
IV stand (with joint)	60122
Get-up support	70362KP
Nurse's locking board	36505
Nurse's control board	46373
Battery	AG7

## 2.2 Removable components

The bed surface plastic boards in a hospital bed are removable. The plastic boards can be removed from the bed for cleaning. See instructions for removing the bed surface plastic boards in chapter 6.11 'Removing and reattaching the plastic boards of bed'.

<b>Removable components</b>	<b>Model</b>
Backrest plastic 80cm	70114
Seat section plastic 80cm	70115
Thigh rest plastic 80cm	70116
Leg rest plastic 80cm	70117
Leg rest plastic 2 parts 80cm	70209
Backrest plastic 90cm	70218
Seat section plastic 90cm	70219
Thigh rest plastic 90cm	70220
Leg rest plastic 90cm	70221
Leg rest plastic 2 parts 90cm	70222

### 3 Acceptance inspection and storage

Check that the transportation package is intact and no damages have occurred during transport. Remove all the packaging material of the bed. Remove also all possible transportation brackets.

The delivery must include all the components included in the shipping list. If defects in the shipment are discovered, contact the supplier immediately.

**IMPORTANT!** *The allowed storage temperature of the bed is between -20 and +50 °C and the allowed humidity of the storage room is between 30 and 75%.*

**IMPORTANT!** *To use the battery system of a bed equipped with one, the battery must be charged for at least 14 hours after storage or before it is first commissioned.*

**IMPORTANT!** *After long-term storage, the battery may need to be charged and discharged several times to reach its peak performance.*

**IMPORTANT!** *The battery is discharged within a few months of storage. Always charge the battery fully before storage of longer than six months. You must charge the battery fully once every 12 months.*

## 4 Safety instructions

Follow these safety instructions.

- IMPORTANT!** *Use only accessories approved by the manufacturer for the specific model of bed.*
- IMPORTANT!** *The mattress must meet the bed manufacturer's requirements for height and width.*
- IMPORTANT!** *Attach the rescue sheet to the adjustable bed surface. Never attach the rescue sheet to the bed frame or through frame components, because it may prevent the adjustment of the bed surface.*
- IMPORTANT!** *Deliberate or unintentional use of the bed's hand-held control must be prevented by placing it out of reach of restless patients and children.*
- IMPORTANT!** *Release the pushbutton of the hand-held control to stop any movement of the bed. In case of malfunction, press the pushbutton of a reverse movement in the hand-held control, nurse's locking board or nurse's control board to stop a movement for the as long as the button is pushed. The movement can also be stopped by locking the function in the nurse's locking board or control board.*
- IMPORTANT!** *Do not press two or more pushbuttons of the hand-held control at the same time.*
- IMPORTANT!** *The electric components under the bed surface heat up when electric operations are used. Avoid unnecessary contact with the electric components under the bed surface. Contact with the components is only allowed during maintenance and cleaning procedures.*
- IMPORTANT!** *Allow the electric components under the bed surface to cool off before carrying out their maintenance or cleaning procedures. Maximum duration of continuous contact between these components and bare skin is 1 minute.*
- IMPORTANT!** *The rails of the bed must be freely adjustable up and down so that the rail is not supported or wedged in the upper position by an external obstacle (mattress, bed linen, mattress air tubes or other object) without engaging the rail's own locking mechanism.*

- IMPORTANT!** *Make sure the rail's locking mechanism works each time you adjust its height (clicking sound). Never tie or prop the bed rail in the upper position with external objects.*
- IMPORTANT!** *Always lock the wheels when the bed is stationary.*
- IMPORTANT!** *The bed must only carry one patient or person at a time.*
- IMPORTANT!** *The hospital bed must always be left in its lowest position to minimize the risk of falling and crushing and to ensure safe operation.*
- IMPORTANT!** *Before adjusting the bed or rails, make sure that nothing and nobody is under them or between their mechanisms (risk of crushing).*
- IMPORTANT!** *When the patient is left without supervision, adjust the bed surface to its lowest position (risk of falling).*
- IMPORTANT!** *If there is the risk that the patient will fall out of the bed, always leave the rails in their upper position when the patient is left without supervision.*
- IMPORTANT!** *Never use the get-up support as a replacement for side rails (danger of crushing).*
- IMPORTANT!** *Never attach anything to the get-up support.*
- IMPORTANT!** *In case of malfunction in the bed or its accessories, decommission it immediately and have it serviced.*
- IMPORTANT!** *Make sure that the surroundings of the bed are safe. Make sure there is adequate room around – and above – the bed. Make sure there are no sharp corners or potentially hazardous objects around the bed.*
- IMPORTANT!** *The adjustment functions of beds with a battery system work after the mains power is disconnected or during a power outage as long as there is power in the batteries. The operations of the bed may be prevented using the nurse's control or locking board.*
- IMPORTANT!** *When operating without mains power, the battery gives a sound signal and stops the movement momentarily when battery power is low. When the battery power is low, operate the bed one movement at a time. Do not use the pushbuttons of the hand-held control, which activate several movements simultaneously.*

- IMPORTANT!** *Never change the structure of the bed or install on it components other than those indicated in this document and approved for the specific product by the manufacturer.*
- IMPORTANT!** *Electrical and mechanical components (excluding the accessories referred to in chapter 7 of the operating instructions 'Installation and use of accessories') may only be installed by service personnel authorized by Lojer service (vocational upper secondary qualification in machine and metal work or equivalent and valid SFS 6002 training in occupational safety in electric work). Instructions for replacing components by service personnel are given in these maintenance instructions.*
- IMPORTANT!** *When using a passenger hoist to lift the patient from the bed, note the ground clearance and dimensions of the bed and follow the instructions of the passenger hoist manufacturer.*
- IMPORTANT!** *Do not attach mains cables of other devices or other wires to the bed. When moving the bed or using its functions, make sure that the cables of other devices are not left under the bed wheels or between the bed's structures.*
- IMPORTANT!** *Always disconnect the equipotential bonding before moving the bed.*
- IMPORTANT!** *The bed meets the electromagnetic compatibility requirements of operating environment referred to in EMC directive 2004/108/EC. Make sure that the bed is not exposed to electromagnetic radiation that exceeds the approved standard limits. (EMC)*

## 4.1 Safe use of power cable

Follow these safety instructions in the use of the power cable.

- IMPORTANT!** *Never tie the power cable to the bed, because a lifting movement may cut it. Make sure that you can quickly unplug the power cable in an emergency.*
- IMPORTANT!** *Always unplug the power cable before moving the bed. Make sure that the cable is not crushed between the bed's structures or wheels.*
- IMPORTANT!** *If the power cable is cut or damaged, unplug it immediately. Only use the original power cable of the bed.*

## 4.2 Symbols used in the hospital bed labels



Figure 2. *Instructions marked with this symbol must always be read and followed carefully.*



Figure 3. *Warning of danger of crushing.*

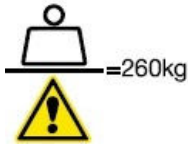

Figure 4. *Safe working load including equipment*



Figure 5. *Maximum allowed weight of patient*



Figure 6. *Follow the operating instruction*



Figure 7. *Warning of requisite action*

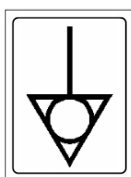

Figure 8. *Label for equipotential bonding*



Figure 9. *Label for protective ground point*



Figure 10. *Product or component marked with this symbol meets the requirements of directive 93/42/ETY (medical devices) and its current amendments.*



Figure 11. *Product or component marked with this symbol is patented internationally*



Figure 12. *Product or component with type B Applied Part*



Figure 13. *Alternating current / AC*

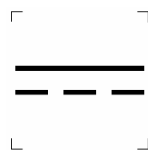

Figure 14. *Direct current / DC*



Figure 15. *Product of component marked with this symbol is TUV SUD certified*





Figure 16. *Product or symbol marked with this symbol may not be processed as household waste; must be disposed of in accordance with EU directive 2002/96. See '12 Recycling'*



Figure 17. *Marking consistent with directives IEC 60601-1 and EN 60601-1. 3<sup>rd</sup> edition*

**IPX6**

Figure 18. *Product or component marked with this symbol has protection consistent with IEC standard 60529*



Figure 19. *Product of component marked with this symbol is intended for indoor use*



Figure 20. *Read the operating instruction*

### 4.3 Warning labels used in the hospital bed

When operating the hospital bed, note the following warning labels attached to its frame and plastic structures and accessories.

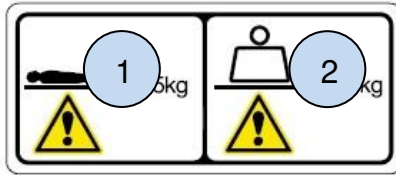

- 1 Maximum allowed weight of patient
- 2 Safe working load including equipment (SWL weight)

Figure 21. *Safe working load (Note! Image is indicative only; check the SWL in the label of the bed)*

Check the weight limits consistent with EN 60601-2-52 (see *Chapter 11 Specifications*).

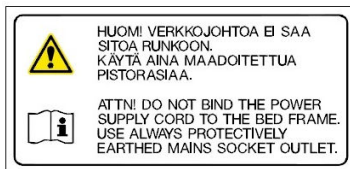

Figure 22. *Warning label for use of power cable*

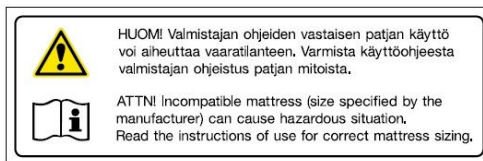

Figure 23. *Warning label for use of mattress*

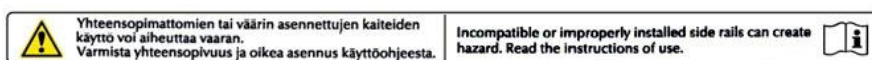

Figure 24. *Warning label for operating rails*



Figure 25. *Warning label for Trendelenburg lever*

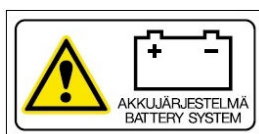

Figure 26. *Warning label for bed equipped with battery system*

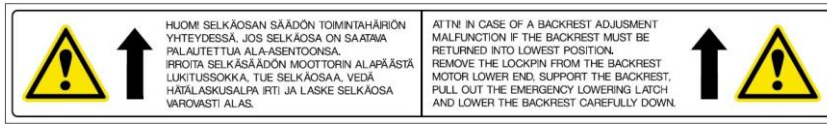

Figure 27. *Warning label for lowering the backrest in case of malfunction*



Figure 28. *Label for following the operating instructions*

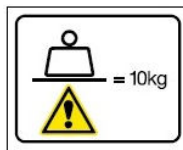

Figure 29. *SWL label (image indicative only)*

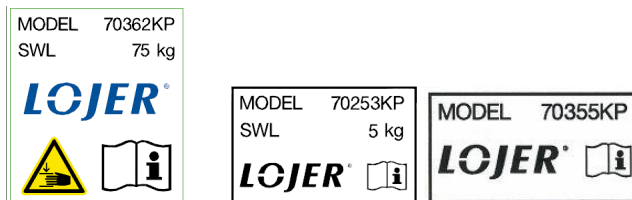

Figure 30. *Labels used in accessories (image indicative only)*

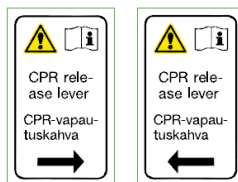

Figure 31. *Warning label for CPR release lever*

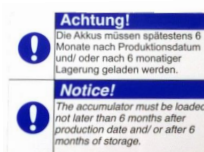

Figure 32. *Label on requisite battery maintenance*



Figure 33. *"Do not open" seal label used in electric components*

## 4.4 Warning labels used in hospital bed packaging

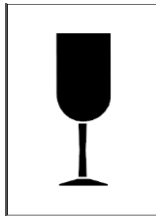

Figure 34. *Fragile*

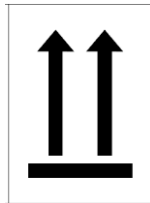

Figure 35. *This side up*



Figure 36. *Store in a dry place*



Figure 37. *Temperature limits for transportation and storage*

## 5 Procedures before use

Carry out the following procedures before operating the hospital bed.

- IMPORTANT!** *Read the operating instructions before operating the hospital bed.*
- IMPORTANT!** *Read the safety instructions, practice using the bed and ask for advice on the safe use of the bed, if necessary!*
- IMPORTANT!** *Plug the hospital bed to 230V ~ 50Hz voltage using a socket with protective earth. Make sure that the distance to the power socket is at least two meters.*
- IMPORTANT!** *Make sure that the power cable is not tied to anything. A tied power cable may be cut when the hospital bed is moved.*
- IMPORTANT!** *Always lock the wheels when the bed is stationary.*
- IMPORTANT!** *Make sure that there is adequate room around, above and below the bed for various functions and mechanisms.*
- IMPORTANT!** *Make sure that the side rails function flawlessly and lock in the upper position.*
- IMPORTANT!** *To use the battery system of a bed equipped with one, the battery must be charged for at least 14 hours after storage or before it is first commissioned.*

## 6 Operating the hospital bed

The hospital bed is meant to be used in normal, dry indoor conditions. The temperature of the room may vary between +10 and + 40 °C and its humidity between 30% and 75%.

**IMPORTANT!** *Never use the electric operations of the hospital bed continuously for longer than the allowed two minutes. Longer continuous use may cause the transformer to overheat. If you use the electric operations continuously for two minutes, pause for 18 minutes consistent with the intermittent operation limits.*

**IMPORTANT!** *If the patient is allowed to adjust the bed unassisted, instruct the patient in safe use and ensure the patient's adequate awareness.*

**IMPORTANT!** *In case of malfunction, the backrest can be manually lowered using the emergency backrest lowering or CPR backrest lowering. See the instructions in chapters '6.5 Backrest emergency lowering' and '7.14 CPR backrest lowering'.*

**IMPORTANT!** *In case of emergency, the hospital bed can be tilted in Trendelenburg or reverse Trendelenburg angles. See instructions in chapter '6.7 Trendelenburg adjustment'.*

### 6.1 Hand-held controls

The hospital beds have hand-held controls for adjusting the bed. In 2 function models, the pushbuttons for adjusting the height of the bed surface and tilt of the backrest. The 4 function models also have pushbuttons for raising and lowering the thigh and leg rests. Some hand-held control models may have a combination button for simultaneous adjustment of different components, for example combined adjustment of backrest and leg rest. In addition, the ICU models may have the Trendelenburg and reverse Trendelenburg adjustment or only the reverse Trendelenburg adjustment.

Depending on the model of hand-held control and bed, the hand-held controls have various LED lights indicating its status. When the bed is plugged in or is connected to battery power, the lower end of the hand-held control has a lit Power On light, a green or yellow LED light, indicating that the power is connected. In beds equipped with a battery, a flashing signal light in the hand-held control shows that the battery is charging. When an adjustment button is pushed in the hand-held control, a green LED light in the top of the control indicates activation, and it will switch off when the button is no longer pushed.

**NOTE!** Hand-held controls equipped with magnetic key locking. The locking function is always used in hand-held controls which are equipped with a Trendelenburg adjustment function. (Note! Not applicable to controls with only the reverse Trendelenburg adjustment).

The hand-held control is activated by pulling a magnetic key once over the locking symbol on the control, which turns the locking symbol light green. This gives access to normal functions: the adjustment of height, backrest and leg rest. This activates the hand-held control into a so-called patient operation mode, i.e. all other operations work except the Trendelenburg. Pulling the key again over the locking point activates the Trendelenburg function. The locking light turns orange, NOTE! Never leave a hand-held control in this mode within the reach of an unsupervised patient. The Trendelenburg mode deactivates automatically after approximately 40 s if the hand-held control is inactive. After this, the hand-held control can be reactivated in patient operation mode by using the locking key.

The ICU models usually have a nurse's control board as standard equipment; it can be used to control the bed just like the hand-held control. Read section '7.6 Operation of nurse's control board' below in this document.

For safety reasons, the beds equipped with a battery have either the nurse's locking board or the nurse's control board as standard equipment. Read more about their operation below in these operating instructions (Operating instructions chapters 7.6 and 7.7).

**IMPORTANT!** *The appearance of and the order of buttons on the hand-held controls may vary depending on the model.*

**IMPORTANT!** *If the hand-held control is within the reach of the patient, operating it may cause danger to the patient or others so we recommend that the operations of the hand-held control are locked.*

**IMPORTANT!** *Never leave a hand-held control in Trendelenburg operating mode within reach of an unsupervised patient. Make sure the hand-held control is in locked or patient operation mode.*

**IMPORTANT!** *Keep the magnetic key in a safe place, inaccessible to persons who are not healthcare professionals.*

**IMPORTANT!** *Release the pushbutton of the hand-held control to stop any movement of the bed. In case of malfunction, press the pushbutton of a reverse movement in the hand-held control or nurse's control board to stop a movement for the as long as the button is pushed. The movement can also be stopped by locking the function in the nurse's locking board or control board. The movement of beds without a battery can be stopped by unplugging the bed's power cable.*

**IMPORTANT!** *Do not press two or more pushbuttons of the hand-held control at the same time when adjusting the bed.*

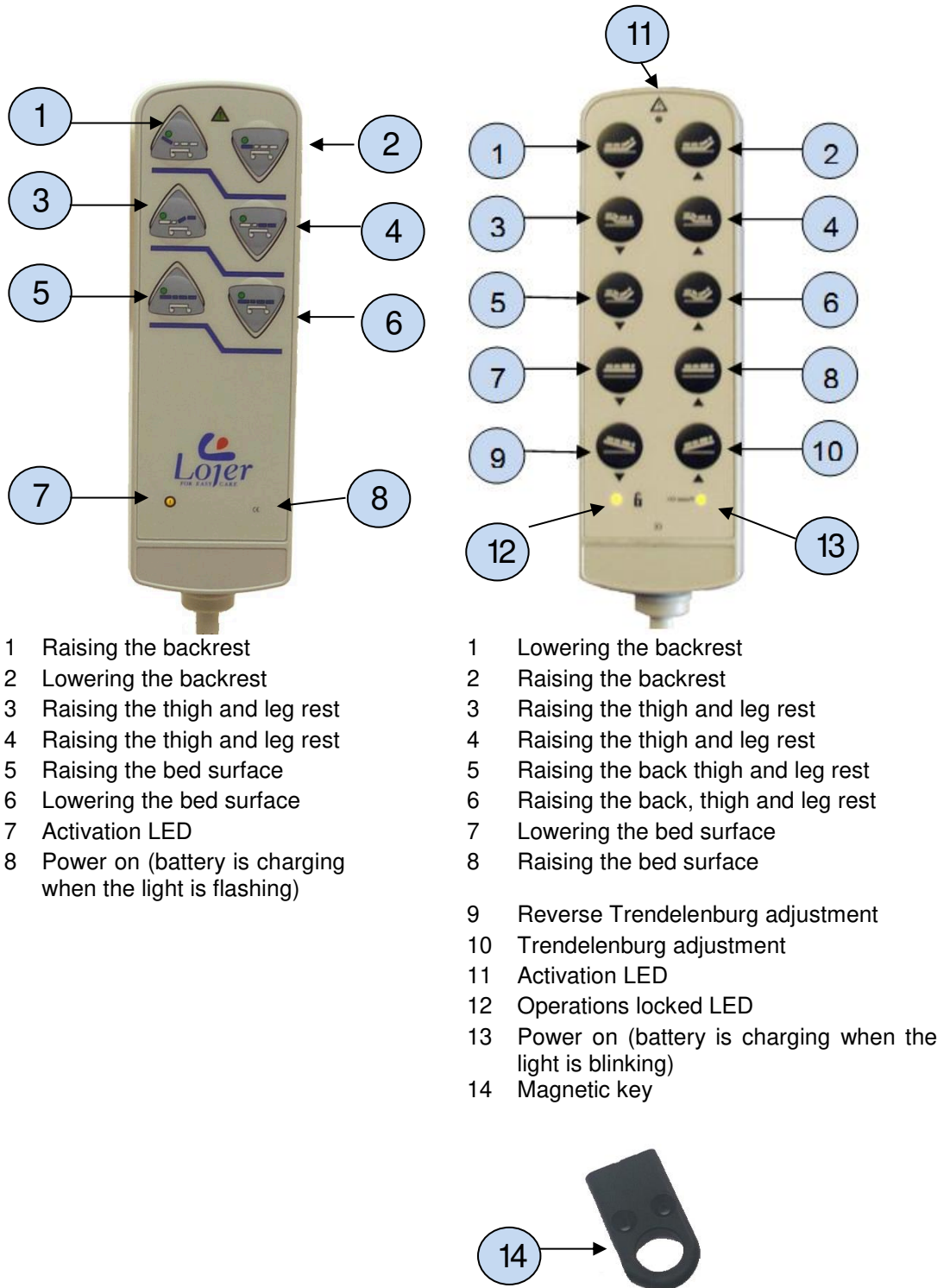

Figure 38. Hand-held control (image indicative only)



## 6.2 Locking the wheels

The hospital bed has centrally locking wheels. In models TK, S and ICU, the central locking is operated with the brake pedals or brake arc.

Lock the wheels by pressing down the pedal or brake arc at the foot end of the hospital bed (see Figures 39 and 40). The wheels turn freely when the pedal or brake arc are in a horizontal position.

A pedal or brake arc in the upper position locks the aligning wheel, i.e. the left front wheel of the head end of the bed. Ensure the aligning wheel lock by moving the head end of the hospital bed sideways.

Due to land-specific differences, the aligning wheel may also be located in the foot end of the bed. However, its operation is the same i.e. the aligning wheel is locked when the brake pedal or brake arc is in the upper position.

**IMPORTANT!** Always lock the wheels when the bed is stationary.

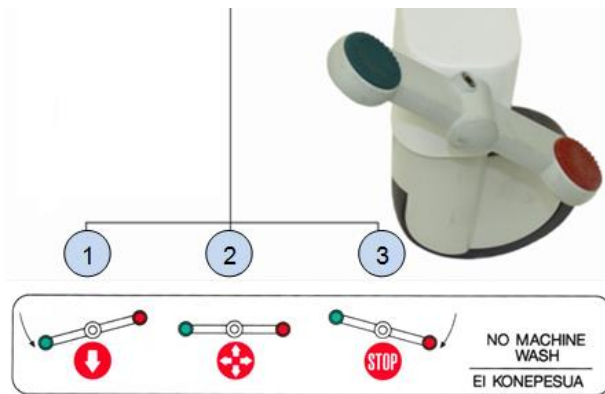

- 1 Green pedal end down – aligning wheel lock on
- 2 Brake pedal in center position – wheels turn freely
- 3 Red pedal end down – wheels are locked

Figure 39. Brake pedal, locking the wheels



- 1 Brake arc in upper position – aligning wheel locked
- 2 Brake arc in horizontal position – wheels turn freely
- 3 Brake arc in lower position – wheels are locked

Figure 40. Brake arc, locking the wheels (wheels are locked in the Figure)

## 6.3 Moving and transporting the bed

- IMPORTANT!** *Move the bed by the foot of the bed where the brake pedals and brake arc are located. The normal way to transport a patient in the bed is head first.*
- IMPORTANT** *Always unplug the power cable before moving the bed. Make sure that the cable is not crushed between the bed's structures or wheels.*
- IMPORTANT!** *Always disconnect the equipotential cable before moving the bed.*
- IMPORTANT!** *We recommend that you disconnect all protruding accessories of the bed to minimize the risk of collision.*
- IMPORTANT!** *To transport the patient, lower the bed surface to its lowest position and raise the rails to minimize the risk of falling.*

## 6.4 Adjusting bed surface height

The height adjustment function of the bed surface is driven by an electric motor. The height of the bed surface can be adjusted within the range of 30-82 cm depending on the bed model and wheel size.

- IMPORTANT!** *Adjust the bed surface to be horizontal before adjusting bed height. (Note! S model beds with gas spring driven Trendelenburg / reverse Trendelenburg adjustment).*
- IMPORTANT!** *Before adjusting the bed or rails, make sure that nothing and nobody is under them or between their mechanisms. (danger of crushing). Be careful when the rails are in the lower position and when lowering the bed surface (danger of crushing).*
- IMPORTANT!** *The hospital bed must always be left in its lowest position to minimize the risk of falling and to ensure safe operation.*
- IMPORTANT!** *Depending on the model, the bed may make a beeping sound when the bed surface lowering button is pushed to indicate that the bed is already in its lowest position.*

Raise or lower the bed surface by pushing the button in the hand-held control (see Figures 41 and 42).

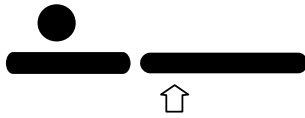

Figure 41. *Raising the bed surface*

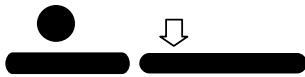

Figure 42. *Lowering the bed surface*



Figure 43. *Danger of crushing in the scissor structure of the bed*

## 6.5 Adjusting the backrest

The backrest angle of the hospital bed is adjustable within the range of 0-70°.

**IMPORTANT!** Make sure your hands are not crushed between the backrest and the upper frame when adjusting the backrest. (danger of crushing).

**IMPORTANT!** There is a danger of crushing when adjusting the get-up support and the bed's backrest.

Raise or lower the backrest by pushing the button in the hand-held control (see Figures 44 and 45).

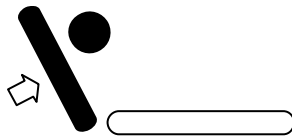

Figure 44. Raising the backrest

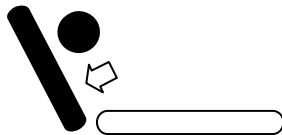

Figure 45. Lowering the backrest

## 6.6 Emergency lowering of the backrest

During power outages and malfunctions, you can manually lower the backrest to its lowest position (0°, see *Chapter 11 Specifications*).

**IMPORTANT!** Make sure your hands are not crushed between the backrest and the upper frame. Use this function only in emergencies and be particularly careful when doing so (danger of crushing).

**IMPORTANT!** Reattach the lower end of the motor with emergency lowering pin and emergency lowering linchpin as soon as possible.

### Emergency lowering of the backrest

1. Support the backrest with your other hand.
2. Remove the emergency lowering linchpin attaching the lower end of the backrest motor.
3. Pull out the emergency lowering pin.
4. Let the backrest down carefully.

### Attachment of the emergency lowering mechanism of the backrest

1. Unplug the bed's power cable and, in beds equipped with a battery, lock the operations on the nurse's locking or control board.
2. Lift the fastening lug of the lower end of the motor to the lug of the upper frame and push the emergency lowering pin through the lugs.
3. Fasten the emergency lowering pin with the emergency lowering linchpin.

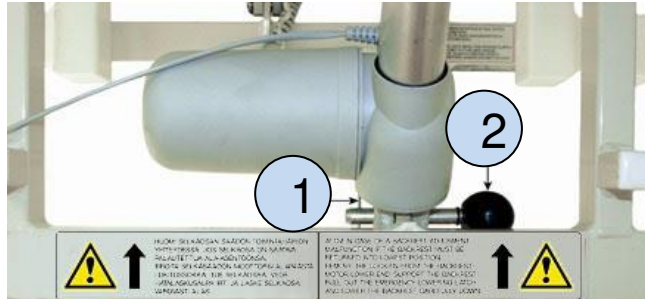

- 1 Emergency lowering linchpin
- 2 Emergency lowering pin

Figure 46. *Emergency lowering mechanism of the backrest*

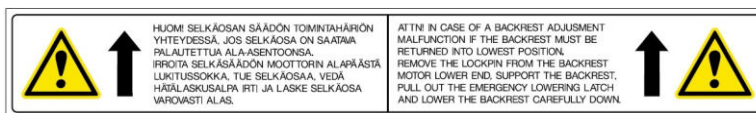

Figure 47. *Returning the backrest in case of malfunction*

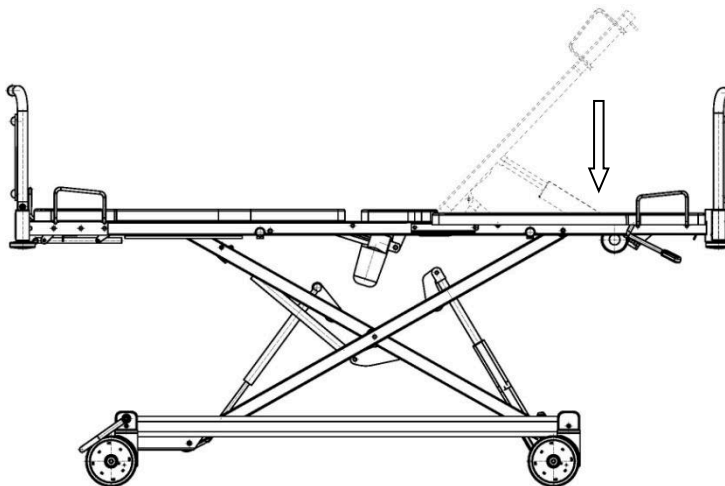

Figure 48. *Backrest lowered into the emergency position.*

**IMPORTANT!** For beds equipped with emergency lowering of CPR backrest, see page 49 Chapter 7.14 Emergency lowering of CPR backrest.

## 6.7 Adjusting the thigh and leg rest

In ScanAfia X TK-480 /490, S-480 / 490 and ICU models, the thigh and leg rests are adjusted electrically.

**IMPORTANT!** Make sure that nothing and nobody is between the leg rest and upper frame when you are adjusting (danger of crushing).

Adjust the thigh rest to the desired angle by pushing the appropriate button on the hand-held control. In the final stage of adjustment, the leg rest is horizontal.

In the lowering operation, the leg rest and thigh rest adjust in the reverse order.



Figure 49. Raising the thigh and leg rest

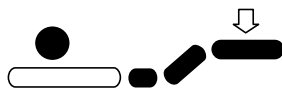

Figure 50. Lowering the thigh and leg rest

## 6.8 Trendelenburg adjustment

The S models of the hospital bed have a Trendelenburg adjustment operated with a gas spring as standard equipment. The bed tilts in Trendelenburg (12°) or reverse Trendelenburg (20°) positions when you pull the handle at the foot of the bed (see Figure 52). When the bed is in the desired angle, release the handle and the bed will remain in the desired position.



Figure 51. Warning label for Trendelenburg adjustment (S models)

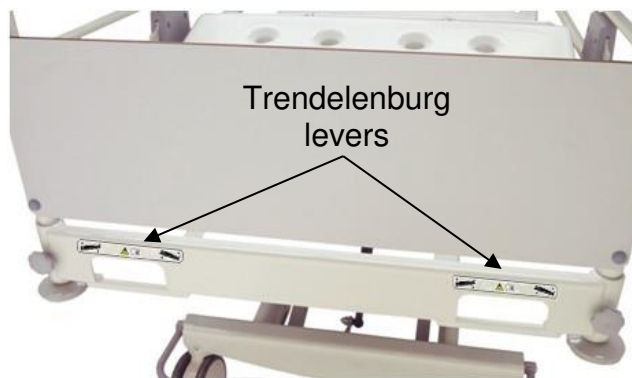

Figure 52. Trendelenburg adjustment (S models)

In ICU models, the Trendelenburg / reverse Trendelenburg adjustment is electrically operated on the hand-held control or the nurse's control board. Adjust the tilt of the bed by pressing the reverse Trendelenburg or Trendelenburg adjustment lever in the desired direction and position. **NOTE!** On the hand-held control, each Trendelenburg operation must be activated with the magnetic key.



Figure 53. *Reverse Trendelenburg adjustment*



Figure 54. *Trendelenburg adjustment*

**IMPORTANT!** *Adjust the bed surface to the horizontal position before adjusting bed height. Never leave an unsupervised patient in the Trendelenburg position.*

**IMPORTANT!** *The reverse Trendelenburg position can only be used when the bed is in the upper position. (danger of crushing) (movement restriction).*

**IMPORTANT!** *Pay attention to the patient's weight when making Trendelenburg or reverse Trendelenburg adjustments and proceed with caution.*

**IMPORTANT!** *Make sure that you return the bed to its horizontal position after Trendelenburg / reverse Trendelenburg position.*

**IMPORTANT!** *S models have gas spring operated Trendelenburg adjustment. If you notice an abnormality in the Trendelenburg function, contact the maintenance personnel immediately.*

**IMPORTANT!** *In ICU models, if one lifting motor has a malfunction, the Trendelenburg angle can be reached using the second lifting motor.*

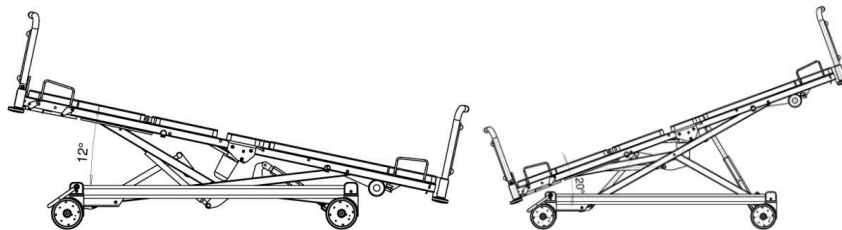

Figure 55. *The bed's Trendelenburg and reverse Trendelenburg emergency positions.*

## 6.9 Equipotential connection

The purpose of the equipotential is to prevent the occurrence of dangerous voltage differences between conductive components that are touched simultaneously. The ScanAfia X hospital beds have the equipotential connection in the front element below the equipotential connector label. Use the equipotential whenever it is needed; note the manufacturer's operating instructions. Attach the equipotential cable to the connector with an appropriate attachment.

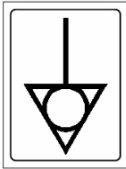

Figure 56. *Equipotential connector label*

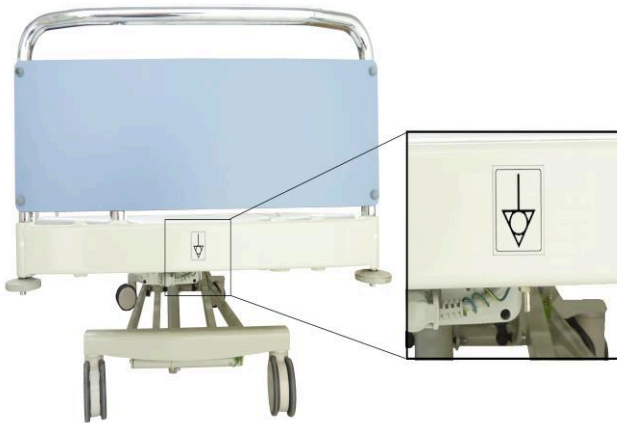

Figure 57. *Equipotential connector at the end of the bed*

**IMPORTANT!** *Always disconnect the equipotential cable before moving the bed.*

## 6.10 Operating the battery of the hospital bed

The battery of the hospital bed is intended for use in emergency situations only, in which no mains power is available, such as during power outages and when moving the bed.

**IMPORTANT!** *The battery sounds a signal and stops the movement for a moment when its power is low. If the battery power is low and bed movements must be run, run them one movement at a time. Do not use the pushbuttons of the hand-held control, which activate several movements simultaneously.*



**IMPORTANT!** Do not run the bed movements daily with battery power. Battery use is intended for emergency situations only when no mains power is available. The bed must be plugged in whenever possible. When the bed is plugged in, the battery charge level is under control and the battery charges automatically.

**IMPORTANT!** To use the battery system of a bed equipped with one, the battery must be charged for at least 14 hours after storage or before it is first commissioned. After charging the batteries, make sure the battery system is in working order before using it.

## 6.11 Removing and fastening the bed surface's plastic boards

The plastic boards can be removed from the bed to facilitate cleaning. The plastic boards are fastened to the metal structure with adhesives. The 2 function and 4 function beds and the beds with a width of 80cm and 90cm have different plastic boards (Figure 58).

Before removing the plastic boards, adjust the bed's backrest, thigh and leg rests in the horizontal position. Remove the bed surface's plastic boards by lifting the board on the side of the bed.

**IMPORTANT!** When attaching the plastic boards to the bed, make sure that the boards you fasten are of the correct shape and width.

**IMPORTANT!** Make sure that the plastic boards are reattached correctly to the bed.

**IMPORTANT!** Make sure that you attach the plastic boards according to Figure 58 below.

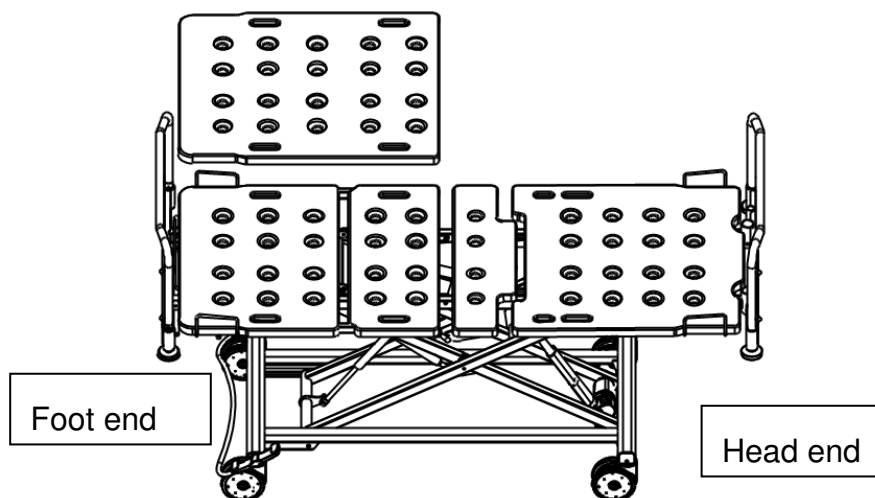

Figure 58. Plastic boards of 2 and 4 function beds

## 7 Installing and operating accessories

This section gives instructions on how to install and operate the accessories of the hospital bed. Accessories are ordered separately.

**IMPORTANT!** *Always use exclusively accessories approved by the manufacturer!*

**IMPORTANT!** *We recommend that you disconnect all protruding accessories of the bed to minimize the risk of collision.*

**IMPORTANT!** *These instructions define the installation and removal procedures for specific accessories. These installation and removal procedures are intended to be performed by the operator. Other accessories are to be installed by service personnel authorized by Lojer.*

### 7.1 Ends (70356KP - 70361KP)

The hospital bed has one painted or chromium plated head of the bed as standard equipment. The ends of the bed available as accessories aim to prevent the patient from falling and to improve patient safety when the rails are used. The head of the bed is not normally attached to the bed (thumbscrews for the head end are available separately). The head end is removed by lifting the end upward. The foot end is fastened with thumbscrews.



Figure 59. *End 80cm 70356KP*

Removing the foot end. Turn the thumbscrews at the lower edge of the end anti-clockwise approximately one cycle and lift out the end.

Fastening the foot end. Make sure that the thumbscrews at the lower edge of the end have been opened at least one cycle. Put the end back in place and tighten the thumbscrews with fingers (Figure 59).

A folding end and a high end are available as accessories to the hospital bed. The folding end can be used as bed making aid. Tilt the end by turning the thumbscrews at the lower edge of the end anti-clockwise one cycle, lift the end and, holding the end by its top arc, pull the end away from the bed. When you return the end to the upright position, make sure that the end is in place and fasten the thumbscrews. The SWL of a folding end is 10kg.

High ends and rails are available as accessories if you are using mattresses that are higher than usual, see Chapter 7.10 Mattress recommendations.



Figure 60. *Folding end 80cm 70358KP folded down for making the bed*

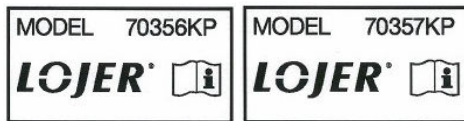

Figure 61. *Labels for ends of widths 80cm and 90cm*

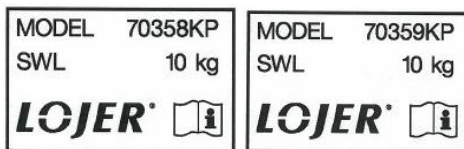

Figure 62. *Labels for folding ends of widths 80cm and 90cm*



Figure 63. *Labels for high ends of widths 80cm and 90cm*



Figure 64. *Correctly installed end of bed*

**IMPORTANT!** Make sure that you install the end correctly so that the arc and end board are not facing the bed (See Figure 64) (danger of crushing).

## 7.2 Long and high side rail (70353KP, 70355KP)

Side rails to improve patient safety are available for the hospital bed as accessories. When using the rails, pay attention to the mattress dimensions recommended by the manufacturer.

The side rails can be adjusted in two positions: the lower and upper positions. Lift the rail in the upper position so that the rail locks in place. When you lower the rail, lift up the adjusting handle of the rail to release the lock and lower the rail down.

Installing and removing the rail: The rail is fastened to the frame of the bed with two spring-loaded lock pins (Figure 65). When you remove the rail, pull the lock pin and at the same time pull the rail away from the bed. When you install the rail, keep the lock pin open and push the rail in place. Make sure that the rail locks in place and is installed correctly with the release handle facing the foot of the bed.



Figure 65. *Rail fastened to the bed*



Figure 66. *Long rails 70353KP installed on the bed*



Figure 67. *High rails 70355KP installed on the bed*

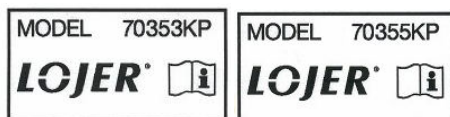

Figure 68. *Labels for a long and a high rail*

**IMPORTANT!** *Before adjusting the bed or rails, make sure that nothing and nobody is under them or between their mechanisms (risk of crushing).*

**IMPORTANT!** *Make sure that the rail locks in the upper position.*

**IMPORTANT!** *To transport the patient, lower the bed surface to its lowest position and raise the rails to minimize the risk of falling.*

**IMPORTANT!** *When the patient is left without supervision, adjust the bed surface to its lowest position (risk of falling).*

- IMPORTANT!** *If there is the risk that the patient will fall out of the bed, always leave the rails in their upper position when the patient is left without supervision.*
- IMPORTANT!** *Make sure that the rail locks in place and is installed correctly with the release handle facing the foot of the bed.*
- IMPORTANT!** *When using the rails, pay attention to the mattress dimensions recommended by the manufacturer.*
- IMPORTANT!** *A correctly installed rail has room to move freely.*

### 7.3 Installing the lift support (101910)

The patient can use the lift support as an aid to get into a comfortable position and to get out of bed.

Install the support into the sleeve at the head end of the bed (see Figure 69) so that it locks with a pin in the sleeve and cannot turn sideways. The support can be installed on the left or the right side of the bed. Each bed should have only one lift support installed.

The support is installed correctly when the handle is hanging above the bed surface and the support does not move sideways.

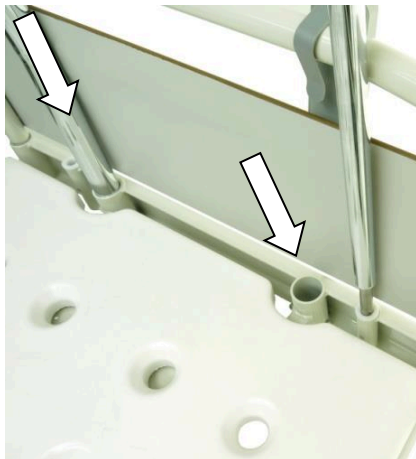

Figure 69. *Installing the lift support*

The SWL of the lift support is 75kg.

MODEL	101910
SWL	75 kg

**LOJER**<sup>®</sup>



Figure 70. *Label of the lift support*

- IMPORTANT!** *Danger of crushing fingers between the lift support and the end of the bed. Exercise caution when installing a lift support in the bed.*
- IMPORTANT!** *Before using the lift support make sure that it is above the bed surface and locked to prevent sideways movement.*
- IMPORTANT!** *Check that there is room above the bed. When you raise the bed, the lift support raises with it.*

## 7.4 Operating the dining tray (70253KP, 70257KP)

The dining tray is used as an auxiliary surface when the patient dines in bed. The dining tray is installed between the raised side rails, nearly in the middle of the rails so that the legs of the tray are on top of the middle rung of the rails and prevented from sideways movement by the rails (Figure 71). The dining tray is available for ScanAfia X beds of widths 80cm and 90cm. The SWL of the dining tray is 5kg.

- IMPORTANT!** *Exercise caution when placing the dining tray on the bed to avoid getting hands or fingers between the dining tray and the rails (danger of crushing).*



Figure 71. *Dining tray placed on the rails*



Figure 72. *Warning labels for dining trays of beds of widths 80cm and 90cm*

- IMPORTANT!** *Before using a dining tray, make sure that the tray is placed firmly between the rails and cannot move sideways (danger of burns).*
- IMPORTANT!** *The dining tray can only be used when the rails are in the upper position.*



## 7.5 Operating the IV stand (60121, 60122)

**IMPORTANT!** Check that there is enough room above the bed. When you raise the bed, the IV stand raises with it.

**IMPORTANT!** When you use the bed, note the stress on the IV stand and the sleeve (Figure 75).

The IV stand is used to hold the infusion fluid and blood preparation bags in intravenous rehydration treatments. The IV stand is installed into the sleeve at the head of the hospital bed (see Figure 73). A standard of two IV stands can be installed on the bed, additional sleeves for the foot of the bed are available as accessories. The IV stand locks when the stand is put into the sleeve and turned until a click sound is heard. The SWL of the IV stand is 2kg.



Figure 73. The installation point and SWL label of the IV stand

The height of the IV stand is adjustable at the leg of the stand. Adjust the height by pushing the adjuster piece up with your fingers and by moving the upper leg of the IV stand. At the same time hold the lower leg of the IV stand so that it is not disconnected from the bed.



Figure 74. Adjusting the height of the IV stand



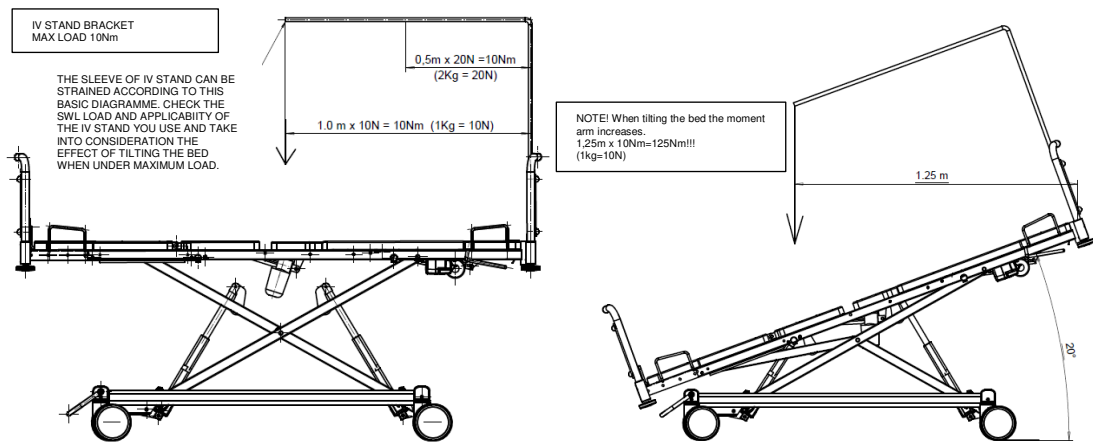

Figure 75. *Stress on the sleeve of the IV stand*

Also other manufacturers' IV stands that fit in the sleeve can be used while taking into consideration the sleeve's maximum load shown in Figure 75. Make sure the stand fits in the sleeve. At the head of the bed, the maximum bending moment of the sleeve is 10Nm and the maximum bending moment of the rear end sleeves, available as accessories, is 5Nm.

## 7.6 Operating the nurse's control board (58128)

The nurse's control board is a separate control device for controlling the operations of the bed the same way as the hand-held control or, if needed, preventing the operations of the hand-held control. The nurse's control board is located in a pipe at the foot end of the hospital bed.

The movement functions of the hand-held control can be prevented by locking the equivalent function on the nurse's control board. Correspondingly, the operating switches of the nurse's control board allow you to bypass the locking mode of the hand-held control, e.g. use of the Trendelenburg function in an emergency situation.

**IMPORTANT!** *If the hand-held control is within the reach of the patient, operating it may cause danger to the patient or others so we recommend the use of the nurse's control and locking board.*

**IMPORTANT!** *The adjustment functions of beds with a battery system work after the mains power is unplugged or during a power outage as long as there is power in the batteries. The operations of the bed may be prevented using the nurse's control or locking board.*

**IMPORTANT!** *When you are using the nurse's control or locking board, make sure that the functions are switched off on the hand-held control.*

**IMPORTANT!** Release the pushbutton of the hand-held control to stop any movement of the bed. In case of malfunction, press the pushbutton of a reverse movement in the hand-held control or nurse's control board to stop a movement for the as long as the button is pushed. The movement can also be stopped by locking the function in the nurse's locking board or control board.

**IMPORTANT!** Do not press two or more pushbuttons of the nurse's control board at the same time.

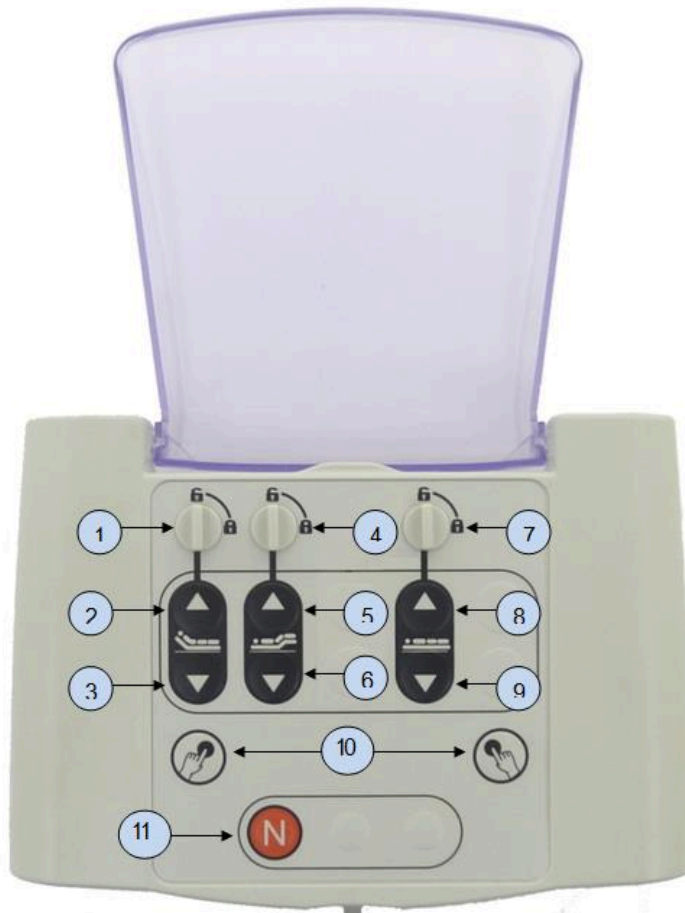

- 1 Backrest adjustment locking / release (in the Figure, the adjustment is released)
- 2 Raising the backrest
- 3 Lowering the backrest
- 4 Thigh and leg rest adjustment locking / release (in the Figure, the adjustment is released)
- 5 Raising the thigh and leg rest
- 6 Lowering the thigh and leg rest
- 7 Bed surface height locking / release (in the Figure, the adjustment is released)
- 8 Raising the bed surface
- 9 Lowering the bed surface
- 10 Function button (adjust by pressing this button and the desired function)
- 11 Restore basic adjustments (back, thigh and foot rest in horizontal position)

Figure 76. Nurse's control board TK and S models



- 1 Backrest adjustment locking / release (in the Figure, the adjustment is released)
- 2 Raising the backrest
- 3 Lowering the backrest
- 4 Thigh and leg rest adjustment locking / release (in the Figure, the adjustment is released)
- 5 Raising the thigh and leg rest
- 6 Lowering the thigh and leg rest
- 7 Raising the back, thigh and leg rest
- 8 Lowering the back, thigh and leg rest
- 9 Bed surface height adjustment locking / release (released in the Figure)
- 10 Raising the bed surface
- 11 Lowering the bed surface
- 12 Locking the Trendelenburg / reverse Trendelenburg adjustment (released in the Figure)
- 13 Increasing the Trendelenburg tilt / decreasing the reverse Trendelenburg tilt
- 14 Decreasing the Trendelenburg tilt / increasing the reverse Trendelenburg tilt
- 15 Sitting position (maximum reverse Trendelenburg, back and leg rests in upper position)
- 16 Simultaneous raising of back, thigh and leg rests, height adjustment to lower position
- 17 Release of CPR function if functions are locked on the upper buttons. In this case, the CPR functions can be used by pressing the release button simultaneously with the CPR function.
- 18 Bed into CPR position (back, thigh and leg rests and height adjustment to lower position)
- 19 Bed surface to highest position
- 20 Shock treatment position (Trendelenburg, back, thigh and leg rests in lower position)
- 21 Release of shock treatment function if functions are locked on the upper buttons. In this case, the shock treatment function is available by pressing the release button simultaneously with the shock treatment button.
- 22 Attention LED (light is on when the levers 1, 4, 9 and 12 or lever 12 are turned to the locked position). NOTE! Use of shock treatment is restricted with the locking.

Figure 77. *Nurse's control board ICU models*

The nurse's control board is attached to the end of the bed with the fastening mechanism on the board. Attach the nurse's control board to the straight point of the pipe at the end of the bed (Figure 78). Make sure that the nurse's control board is not at a bent point of the pipe so that it may become disconnected.

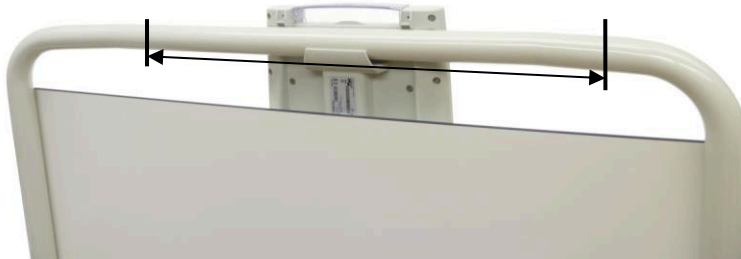

Figure 78. *Fastening the nurse's control board on a straight point of the pipe at the end of the bed*



Figure 79. *The nurse's control board installed at the end of the bed*

## 7.7 Operation of the nurse's locking board (36505)

The nurse's locking board is a separate control device for preventing the functions of the hand-held control, if needed (see Figure 80). The nurse's locking board is installed permanently at the foot of the hospital bed.

The movement function selected on the hand-held control can be prevented by locking the equivalent function on the nurse's locking board.

**IMPORTANT!** *When the bed is unplugged or during a power outage, the bed's adjustment functions operate on a bed equipped with the battery system for as long as the batteries have power. The operations of the bed may be prevented using the nurse's control or locking board.*

**IMPORTANT!** We recommend the use of the nurse's control or locking board if the hand-held control is within the reach of the patient and using it may cause danger to the patient or others.

**IMPORTANT!** When you prevent functions on the nurse's control or locking board, make sure that the functions are switched off on the hand-held control.

**IMPORTANT!** Release the pushbutton of the hand-held control to stop any movement of the bed. In case of malfunction, press the pushbutton of a reverse movement in the hand-held control, nurse's locking board or nurse's control board to stop a movement for the as long as the button is pushed. The movement can also be stopped by locking the movement on the nurse's locking board or control board.

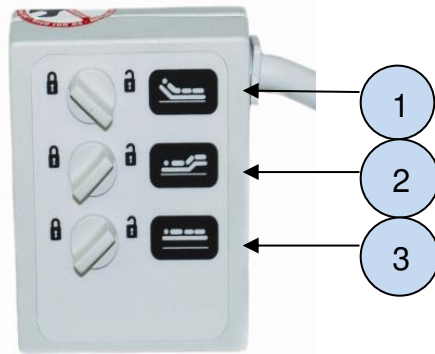

1. Backrest adjustment locking / release
2. Leg and thigh rest adjustment locking / release
3. Bed surface height adjustment locking / release

Figure 80. Nurse's locking board (backrest adjustment function locked)

## 7.8 Urine bag stand (70379)

The urine bag stand is used to attach a urine bag under the upper frame of the bed. Install the urine bag stand on the bed by lifting the side end. Lift up the center plastic board of the bed, which is attached with adhesives. Push the urine bag stand through the holes in the pipe on the side of the upper frame (Figure 81). Once the urine bag stand is in place, lower the center plastic board back in place so that the urine bag stand stays in place.

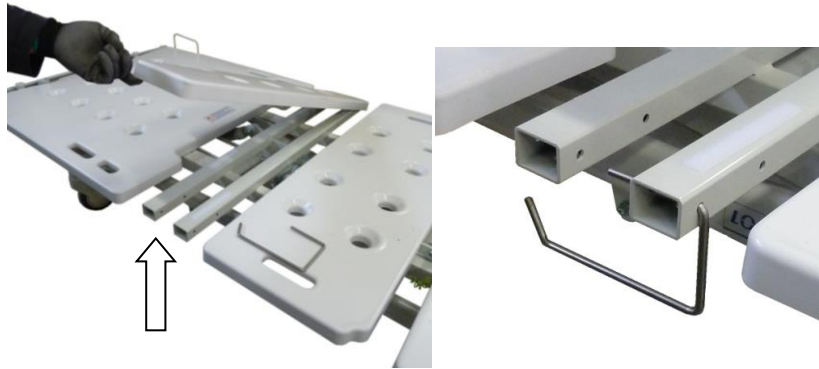

Figure 81. *Installing the urine bag stand*

**IMPORTANT!** *The urine bag stand cannot be used in connection with the get-up support.*

## 7.9 5. Wheel (70363KP)

The fifth wheel is an accessory, which facilitates steering the bed during transport and reduces the turning radius. When using the fifth wheel, the left front wheel no longer works as an aligning wheel, but is replaced by a normal brake wheel. The fifth wheel can be on all the time because it does not prevent moving the bed sideways in normal circumstances. When moving the bed sideways, the fifth wheel can however be lifted up to facilitate moving. Commission the fifth wheel by pressing down the pedal arc of the wheel at the point indicated by the arrow in Figure 82 so that the fifth wheel lowers to the floor. Decommission the wheel by lifting the pedal arc of the fifth wheel with the top of your foot at the point indicated with the arrow in Figure 82.



Figure 82. *5. wheel*

**IMPORTANT!** *We recommend that the fifth wheel is decommissioned when the bed is pushed over thresholds and raised parts of floor.*



## 7.10 Mattress recommendations

Several mattresses with different features are available for hospital beds. Use the following mattress dimensions recommended by the manufacturer with rails 70353KP.

Bed model	Mattress dimensions (width x length x height)
80cm wide	78cm x 205cm x 13cm
90cm wide	88cm x 205cm x 13cm

Mattresses with the required dimensions available at the manufacturer are:

- Fysicon 8193 or 8193-88 (78cm or 88cm wide mattress)  
(Finlayson Fysicon basic 45026-0743-26 or 45026-0742-86)
- Mediflex 8194 or 8194-88  
(Finlayson Pro Mediflex safe 45026-7904-26 or 45026-7904-36)

Use the following mattress dimensions recommended by the manufacturer with rails 70355KP.

Bed model	Mattress dimensions (width x length x height)
80cm wide	78cm x 205cm x 16cm
90cm wide	88cm x 205cm x 16cm

Mattresses meeting the requirements are e.g.:

- Fysicon MiniMAX (78cm or 88cm x 16cm x 205cm)

**IMPORTANT!** With high rails and bed ends, use mattresses which meet the required dimensions but are 16cm - 21cm high.

**IMPORTANT!** When using a mattress other than one recommended by the manufacturer, make sure that the mattress meets the requirements of section 201.15.4.102 of standard 60601-2-52.

**IMPORTANT!** The mattress must meet the bed manufacturer's requirements for height and width.

**IMPORTANT!** The rails of the bed must be freely adjustable up and down so that the rail is not supported or wedged in the raised position by an external obstacle (mattress, its air tubes or other object) without engaging the rail's own locking mechanism.

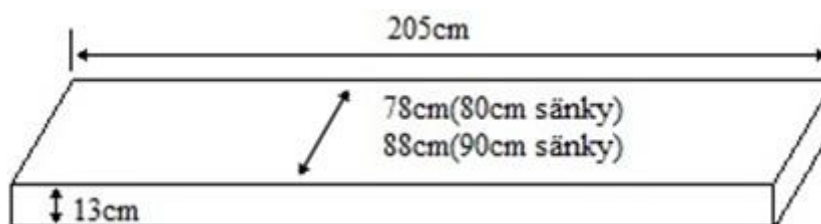

Figure 83. Mattress dimensions for 80cm and 90cm wide beds

## 7.11 Battery (AG7)

A battery system is available as accessory for S and TK model hospital beds which allows the use of bed functions when mains power is not available. Batteries are standard equipment in ICU models.

The ScanAfia X hospital beds use 1.2 Ah lead gel batteries.

**IMPORTANT!** *The battery is meant for emergency power source when mains power is not available. The bed must be plugged in whenever possible. When the bed is plugged in, the charge level of the battery is under control and the battery is charged automatically.*

**IMPORTANT!** *The battery sounds a signal and stops the movement for a moment when its power is low. If the battery power is low and bed movements must be run, do so one movement at a time. Do not use the pushbuttons of the hand-held control, which activate several movements simultaneously.*

**IMPORTANT!** *To use the battery system of a bed equipped with one, the battery must be charged for at least 14 hours after storage or before it is first commissioned.*

**IMPORTANT!** *The battery is discharged within a few months of storage. Always charge the battery fully before storage of longer than six months. You must charge the battery fully once every 12 months.*

**IMPORTANT!** *After long-term storage, the battery may need to be charged and discharged several times to reach its peak performance.*

**IMPORTANT!** *The bed's control system uses a small amount of current although the bed functions are not used. This may result in full discharge of the battery, which may damage it.*

**IMPORTANT!** *See section 9.3 Battery maintenance procedures in these operating instructions.*

**IMPORTANT!** *In beds equipped with the battery system, the bed adjustment functions operate even after the bed is unplugged or during a power outage for as long as the batteries have power. The operations of the bed may be prevented using the nurse's control or locking board.*

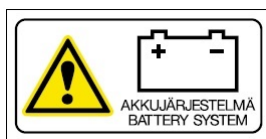

Figure 84. Warning label of beds equipped with a battery system



## 7.12 Bed surface extension (70330KP, 70331KP)

The hospital beds have an extension option for tall patients.

### Installing the bed surface extension on the bed:

1. Lock the bed wheels.
2. Lift to remove the bed end at the foot of the bed to facilitate installing the extension.
3. Remove the plastic board of the leg rest, remove the four thumbscrews of the rear bed end on both sides of the upper frame (Figure 85) and support the rear end so it does not fall.



Figure 85. *Thumbscrews of the rear bed end*

4. Extend the bed by pulling the rear bed end away from the bed until the two last screw holes of the rear bed end align with the holes in the upper frame of the bed, reattach the thumbscrews and tighten with fingers (Figure 86).

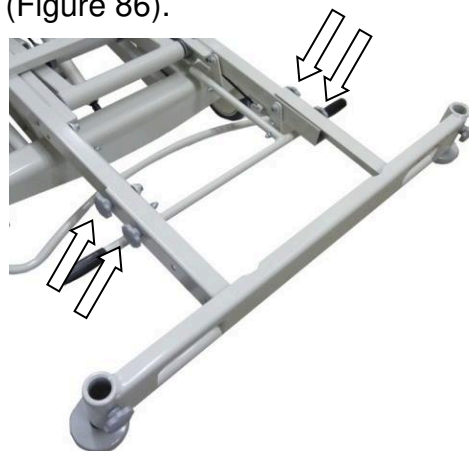

Figure 86. *Rear bed end extended and thumbscrews fastened*

5. Place the bed surface extension in the frame of the leg rest so that the holes in the extension board align with the leg rest frame (Figure 88).



Figure 87. *Attaching the bed surface extension*

6. Fasten the bed surface extension with four wing screws (Figure 88).



Figure 88. *Bed surface extension fastened with wing screws*

7. Place the leg rest plastic board back in place.
8. Place the bed surface extension cushion back in place.
9. Place the bed end back in place in the rear end.

#### **Removing the bed surface extension from the bed:**

1. Lock the bed wheels.
2. Remove the bed surface extension cushion.
3. Remove the plastic board of the leg rest.
4. Remove the four wing screws which fasten the bed surface extension to the leg rest frame and remove the bed surface extension (Figure 88).
5. Remove the four thumbscrews of the rear bed end and support the rear bed end (Figure 86).
6. Push the rear bed end toward the front of the bed until the two closest screw holes of the rear bed end align with the holes in the bed frame.

7. Fasten the thumbscrews while supporting the rear bed end (Figure 85).
8. Fasten the plastic board of the leg rest.

**IMPORTANT!** *The bed surface extension includes an extension of the Trendelenburg handle in the S models.*

**IMPORTANT!** *In ICU models with 150mm design wheels, the bed surface extension excludes the bumper wheels; in beds with 125mm wheels, the extension excludes the bumper wheels at the foot of the bed.*

## 7.13 Trendelenburg handle

The Trendelenburg adjustment is included in the bed surface extension accessory. In beds with the bed surface extension, the Trendelenburg handle is used as an extension handle so that the Trendelenburg adjustment is easier.

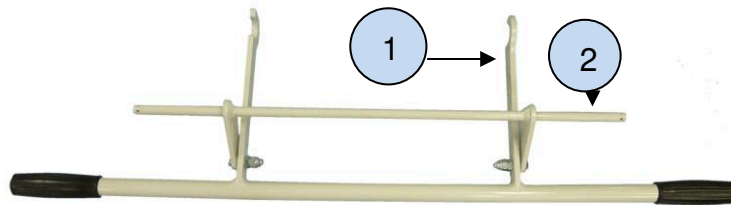

- 1 Extension handle hook
- 2 Rocker shaft pin of the extension handle

Figure 89. *Trendelenburg handle*

Installing the Trendelenburg handle on the bed:

1. Install the bed surface extension according to the instructions in chapter '7.12 Installing the bed extension'.
2. Lift the bed surface to the upper position to easier install the Trendelenburg handle.
3. Install the Trendelenburg handle in place by lifting the extension handle hook, point 1 indicated in Figure 90, on top of the profile of the Trendelenburg handle in the bed.
4. Push the extension handle's rocker shaft pin, point 2 in Figure 90, through the right-hand hole in the extended rear end of the bed (Figure 91).

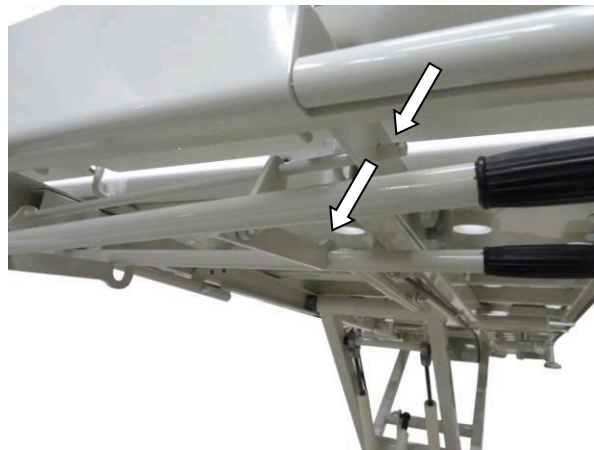

Figure 90. *The shaft pin and extension handle hook in place on the right hand side.*

5. Push the shaft pin through the left-hand hole in the extended rear end of the bed.
6. Lock the shaft pin in place at both ends with lynchpins (Figure 92).



Figure 91. *An installed handle in its place*

Removing the Trendelenburg handle:

1. Lift the bed surface to the upper position to easier remove the Trendelenburg handle.
2. Remove the lynchpins from both ends of the shaft pin (Figure 91).
3. First, pull the left-hand shaft pin out of the hole in the extended rear end of the bed.
4. Pull the right-hand shaft pin out of the hole in the extended rear end of the bed and lift the right-hand extension handle hook off the Trendelenburg handle profile (Figure 91).

## 7.14 **Emergency lowering of CPR backrest (70342KP, 70345KP)**

In the ScanAfia X hospital beds equipped with the emergency lowering of CPR backrest, the backrest can be lowered quickly to the lower position (0°, see *Chapter 11 Specifications*).

The beds equipped with CPR functions have handles at the head of the bed surface below the backrest.

To use the CPR emergency lowering, lift up the handle (Figure 92).



Figure 92. *CPR release handle*

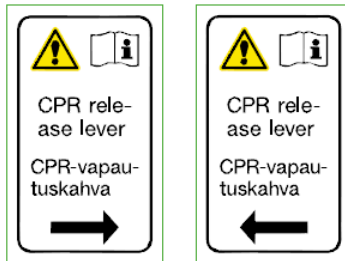

Figure 93. *Warning label of the CPR release handle*

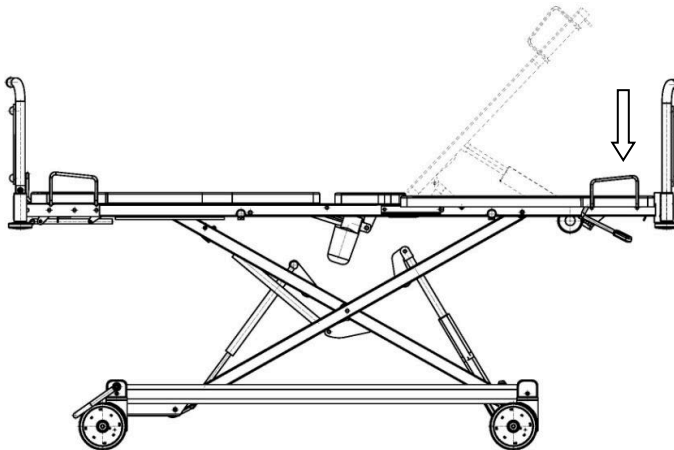

Figure 94. *Backrest lowered to the horizontal position*

**IMPORTANT!** Be careful not to crush your hands between the backrest and the upper frame. Use the CPR function only in case of emergency and exercise caution (danger of crushing).

## 7.15 Quick mounting frame (70364KP)

The quick mounting frame is a separately ordered accessory of the ScanAfia X hospital and treatment beds, which allows you to attach to the bed the get-up support, hand-held control stand and other possible accessories.

The quick mounting frame is installed on the bed in the following order:

1. Lift up the rail and lift the plastic of the seat section attached with adhesives to make installation easier.
2. Place the mounting plate inside the transverse profiles of the bed frame and align the holes of the mounting plate and the bed frame profiles (Figure 95). Place the seat section plastic back in place.

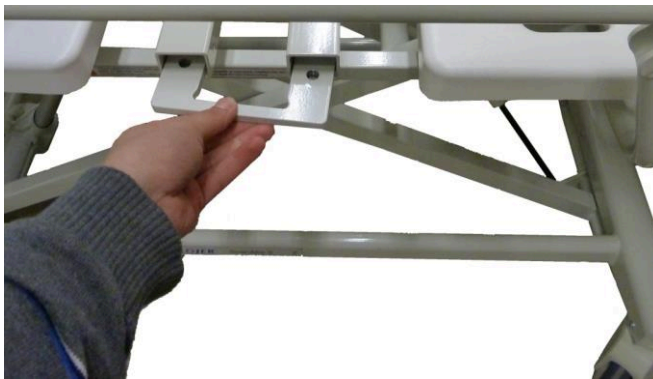

Figure 95. *Installing the mounting plate*

3. Place the guard bar of the mounting frame under the bed frame to face the backrest and align the holes. First, tighten the two screws of the mounting frame with fingers and then use the quick mounting plate of the get-up support to tighten the screws.



Guard bar of the quick mounting frame faces the backrest!

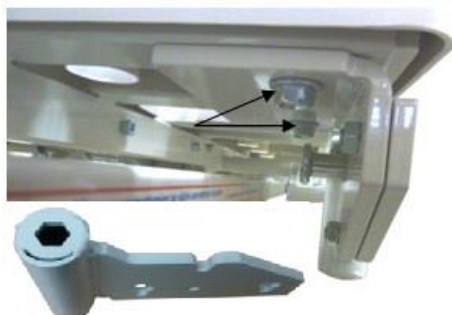

Figure 96. *Fastening the mounting frame of the get-up support*



## 7.16 Get-up support (70362KP)

The get-up support helps the patient to get in and out of bed. The SWL of the get-up support is 75kg.

This get-up support can be used with the ScanAfia X hospital and treatment beds. Make sure the support and the bed are compatible before installation.

**IMPORTANT!** *Make sure that the surroundings of the bed are safe. Make sure there is adequate room around – and above – the bed. Make sure there are no sharp corners or potentially hazardous objects around the bed. When the bed is raised also the get-up support moves and more space is needed.*

**IMPORTANT!** *Never have the get-up support handle turned toward the bed.*

**IMPORTANT!** *We recommend that the get-up support handle is removed when the patient is asleep or the side rails are raised up.*

**IMPORTANT!** *Never use the get-up support as an accessory replacing the side rail (danger of crushing and falling).*

**IMPORTANT!** *Never attach anything to the get-up support.*

**IMPORTANT!** *Check regularly that the fastening of the get-up support operates and is firm.*

**IMPORTANT!** *There is a danger of crushing when using the get-up support and the side rails.*

**IMPORTANT!** *There is a danger of crushing when adjusting the get-up support and the backrest.*

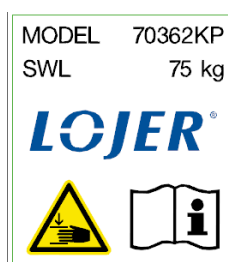

Figure 97. *Warning label of the get-up support*

If a quick mounting frame has not been installed on the bed, start installing the get-up support with Chapter '7.15 Quick mounting frame'. The get-up support is installed on the bed in the following order:

1. Place the quick mounting plate of the get-up support into the mounting frame as indicated in Figure 98 so that the metal profile of the quick mounting plate is facing the backrest. Make sure that the locking pin of the mounting frame locks the quick mounting plate in place.

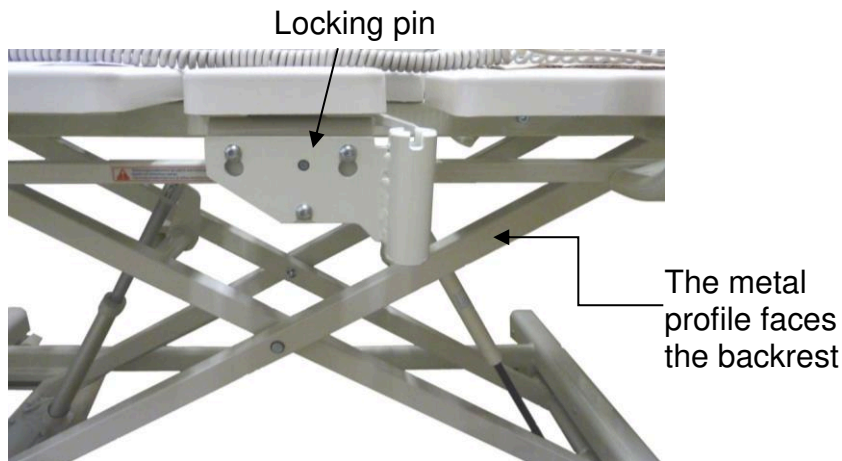

Figure 98. *An installed quick mounting plate*

2. Place the get-up support handle in the mounting frame of the get-up support and make sure that the get-up support handle locks into the slots of the swinging arm.
3. Make sure by the handle that the get-up support frame is firmly fastened to the bed.

**IMPORTANT!** *When the installation is performed correctly, the rails have room to move freely.*

**IMPORTANT!** *The get-up support locks in two different positions. The arm pointing outward from the bed or toward the foot of the bed (Figure 99).*

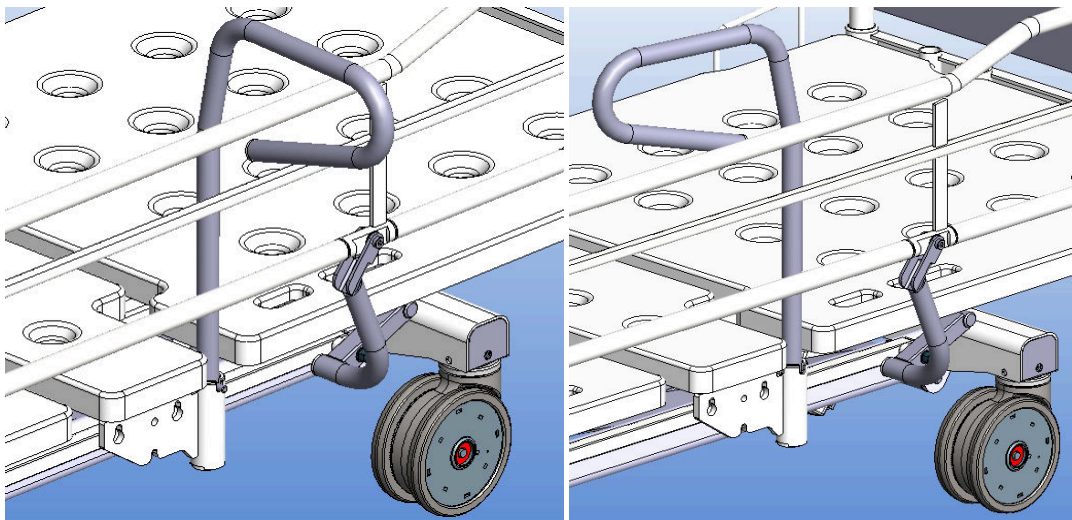

Figure 99. *An installed get-up support*

## 7.17 Stand for the hand-held control (70197KP)

The stand for the hand-held control is a bracket for the hand-held control in the ScanAfia X hospital and treatment beds. If a quick mounting frame has not been



installed on the bed, start installing with Chapter '7.15 Quick mounting frame'. The stand for the hand-held control is installed on the bed in the following order:

1. Place the quick mounting plate of the hand-held control stand into the mounting frame as indicated in Figure 100 so that the metal profile of the quick mounting plate is facing the backrest.
2. Make sure that the locking pin of the mounting frame locks the quick mounting plate in place.
3. Place the arm of the hand-held control stand into the quick mounting plate and tighten the thumbscrew of the hand-held control stand with fingers at the bottom of the quick mounting plate.

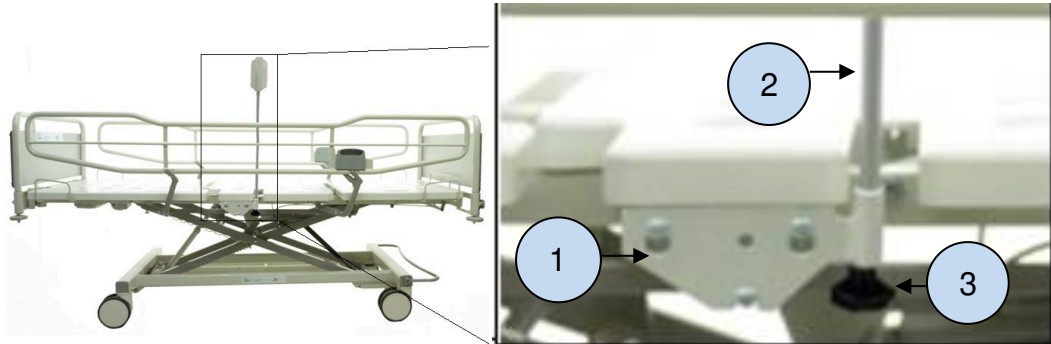

- 1 Quick mounting plate
- 2 Arm of the hand-held control stand
- 3 Thumbscrew

Figure 100. *An installed hand-held control stand*

## 7.18 Limb restraint handles (70367)

The ScanAfia X beds have integrated points in the plate stand for the limb restraints. The limb restraints are used to ensure the safety of a restless patient. Additional handles for limb restraints to be separately installed on the head end are available (70367).

**IMPORTANT!** *Be careful, vigilant and follow the instructions of the limb restraint manufacturer when using the limb restraints.*

**IMPORTANT!** *We recommend that bed surface adjustments other than the height adjustment are not used when the patient is in limb restraints.*

## 7.19 Cushioned rail guard

A cushioned rail guard can be installed on ScanAfia X hospital bed. The guard prevents legs and arms from getting between the rails. The guard is cushioned on the inside to prevent the patient from getting hurt against the rails.

1. Pull the rail guard over the rail so that the rail guard opening is in line with the rail handle (Figure 101).

2. Fasten the rail guard around the rail with the Velcro tape on the bottom edge of the rail guard.

You need not remove the rail guard when lowering the rail.



Figure 101. A rail guard installed on the rail

**IMPORTANT!** Make sure that the bed operations function normally after you have installed the rail guard.

## 7.20 Rack for crutch and cane (101971)

Install the rack for crutch and cane in the sleeve meant for an IV stand (Figure 102). The SWL of the rack is 2kg.



Figure 102. Rack for crutch and cane and their warning label

## 8 Cleaning and disinfecting

Remove all accessories before cleaning.

Remove the power cable. In beds with a battery system, prevent all operations on the nurse's control or locking board and check with the hand-held control that all operations are prevented.

Remove stains as soon as possible.

Clean the device regularly to keep all its surfaces in good condition. Clean/disinfect every time the patient changes. Perform a more thorough cleaning once a month. Follow also the instructions for cleaning/disinfecting issued by the institution/hospital.

**IMPORTANT!** *Allow the electrical components under the bed surface to cool off before carrying out their maintenance or cleaning procedures. Maximum duration of continuous contact between these components and bare skin is 1 minute.*

### 8.1 Metal and plastic surfaces

Clean the metal and plastic surfaces and possible controls with a damp cloth and mild detergent. Use a small brush to clean narrow spaces. Rinse the surfaces with clean water, if needed, and dry them thoroughly. Avoid using excessive amounts of liquids.

When you use a disinfectant (alcohol/chlorine), follow the manufacturer's instructions on diluting and use. Allow the disinfectant to evaporate in room temperature.

Plastic surfaces (ABS, HDPE, PP) have good tolerance of different chemicals. Plastic tolerates bleaching agents (alkaline compounds). Organic and inorganic acids must be diluted. Various solvents and detergents can also be used (check the instructions for use of each product for safe contents).

Plastic surfaces may be damaged if they are exposed to aromatic hydrocarbons (benzene or its derivatives), ketones, ethers or chlorinated hydrocarbons. Note that plastic deteriorates over time if it is exposed to several different chemicals simultaneously.

Stainless steel has good tolerance of chemicals. Use a mild detergent for cleaning. Ammonium and several solvents can be used for demanding removal of stains. Avoid chlorine-based substances.

Painted and chromium coated surfaces can be cleaned with a mild detergent. The surfaces have also good tolerance of chemicals. Avoid using abrasive substances.

- IMPORTANT!** *Follow the instructions of the substance manufacturer on diluting and use of the substance.*
- IMPORTANT!** *All surfaces must be dry before the device is operated.*
- IMPORTANT!** *Always unplug the power cable before cleaning the device.*
- IMPORTANT!** *Note. In devices equipped with a battery, the electrical adjustment operations function even when the power cable is unplugged. Prevent the use of the bed's operations on the nurse's control or locking board.*
- IMPORTANT!** *Never wash the device with a water spray or mechanically.*
- IMPORTANT!** *Never clean the device at high temperature or in high humidity.*
- IMPORTANT!** *Never expose the device to excessive humidity, which may result in liquid accumulation and damage to the device.*
- IMPORTANT!** *Never use solvents, petrol or acids for general cleaning of the device. See above for country-specific instructions.*
- IMPORTANT!** *Dry all surfaces carefully after cleaning and disinfecting.*
- IMPORTANT!** *Disinfecting wears out surfaces. After disinfecting, clean the surfaces with a clean, damp cloth. Dilute the disinfectants following the manufacturers' instructions.*

The bed surface components are attached with adhesives and can be removed for cleaning and disinfecting. Make sure that the cleaned components of the bed surface are appropriately reattached in the correct places.

## 8.2 Hygiene mattress

Remove all secretions and impurities from the mattress as soon as possible and at the latest when the patient changes. We recommend that you air out the mattress periodically to remove possible humidity. Never wash the inside of the mattress, because it may damage the structure of the mattress and its features.

Wash the hygiene film carefully with warm water (50°) and neutral (pH7) detergent. Finally, rinse with clean water, wipe until dry and leave to dry in room temperature and check that the surface of the mattress is dry before it is used. Use a small brush to clean corners and to remove demanding stains. If needed, dilute the detergent following the manufacturer's instructions.

Disinfect the hygiene film of the mattress with an alcoholic detergent. Using excessively strong/powerful disinfectant deteriorates the surface of the hygiene film and shortens the service life of the mattress. We do not recommend the use of detergents containing chlorine.

**IMPORTANT!** *Alcohol dries/makes brittle the surface of the hygiene film so use consideration when disinfecting with an alcoholic detergent.*

## 8.3 Wooden surfaces and other materials

The laminated materials at the ends of the hospital beds and other equivalent materials are washed with water and mild detergents. Alcoholic detergents can be used to remove demanding stains and to disinfect. Rinse with clean water after washing and wipe the surface dry with a towel or cloth. Never use polish.

## 9 Service

Lojer beds require little servicing because the electrical devices on the bed are service-free and the moving parts are lubricated with grease. In normal use and when cleaned as instructed in the operating instructions, the lubrication should not come off.

Never use a defective bed. All the original components of the bed are available at the manufacturer; we recommend that broken or worn components are replaced with these.

The inspections defined in Maintenance procedures (9.1) are intended to be performed by the bed operator. The annual procedures (9.2) are performed by service personnel authorized by Lojer (vocational upper secondary qualification in machinery and metal sector or equivalent and a valid SFS 6002 electric work safety training) or otherwise qualified to service medical equipment. Instructions for replacing components (all components excluding the removable parts) by service personnel are given in these maintenance instructions.

**IMPORTANT!** *Allow the electrical components under the bed surface to cool off before carrying out their maintenance or cleaning procedures. Maximum duration of continuous contact between these components and bare skin is 1 minute.*

**IMPORTANT!** *Before starting service procedures, make sure that the power cable is unplugged and the operations of the device are switched off by trying to use them on the hand-held control or nurse's control board.*

**IMPORTANT!** *Before performing service/repair procedures, the person performing them must read the operating instructions and follow safety instructions.*

**IMPORTANT!** *In beds equipped with the battery system, the bed adjustment functions operate even after the bed is unplugged or during a power outage for as long as the batteries have power. The operations of the bed may be prevented using the nurse's control or locking board.*

**IMPORTANT!** *Electrical or mechanical components can only be installed on the bed by service personnel authorized by Lojer (vocational upper secondary qualification in machinery and metal sector or equivalent and valid SFS 6002 electric work safety training) or personnel otherwise qualified to service medical equipment. Instructions for replacing components by service personnel are given in these maintenance instructions.*

**IMPORTANT!** *Service and repair of the device can only be performed by a person who is adequately qualified or trained for the task. Service by an unauthorized person may result in physical injury or damage to the device for which the manufacturer is not liable.*

**IMPORTANT!** *Always use the original components of the manufacturer and follow the manufacturer's recommendations.*

**IMPORTANT!** *Make sure the bed functions correctly after performing service/repair procedures.*

**IMPORTANT!** *If some component fails to function, unplug the bed and decommission it immediately. In the case of beds with a battery system, unplug the power cable and prevent operations on the nurse's locking or nurse's control/locking board. Contact the service personnel.*

## 9.1 Maintenance procedures

Check the condition and operation of the following points at least every six months:

- power cable and its point of attachment on the device
- cable to motors
- hand-held control and its cable
- rails (test operation)
- brakes
- operation of the emergency lowering mechanism and fastening of the emergency lowering linchpin

**IMPORTANT!** *Check the performance of the battery by lifting the bed surface from the lower position to the higher position back and forth for 2 minutes with a person weighing 70-100 kg on top of the bed. Before starting the test, charge the battery for at least 14 h by keeping the bed plugged in and unplug the bed just as you start the test.*

## 9.2 Annual procedures

**IMPORTANT!** *Copy the page of the annual inspection form (p 59) and fill it out when you perform the annual maintenance procedures. Archive the completed maintenance document.*

Once a year, inspect for possible damages, breaches, deformations and signs of unusual wear:

- rails
- accessories
- structures of the bed surface

- control units
- bed frame structures
- motors and gas springs

Instructions for brake adjustment and other service and repair procedures are given in a separate service instruction (see *Chapter 14 References*).

Inspect the condition of the bed's electrical equipment and cabling, breaches, attachments of cables and strain reliefs, condition of the plug, signs of wear and rubbing on cables and tightness of screw connections in the following points:

- nurse's control board/nurse's locking board
- hand-held control
- control unit
- electrical cabling
- accessories

Perform annually a standardized leakage current measurement to ensure the operation of grounding.

**IMPORTANT!** *If the control unit or power cable is replaced, we recommend that a standardized measurement of leakage current is performed to ensure the operation of grounding.*

**IMPORTANT!** *A defective control unit is always replaced with a new one.*

**IMPORTANT!** *Inspect the condition of motors, gas springs, brakes and wheels with special care and more often if the load of the bed is considerable, i.e. its continuous load is the maximum load (SWL) or the bed is raised more than 3000 times per year.*

The rails must meet the dimension requirements given in standard EN 60601-2-52: 2010. Check that the dimensions of the rails fulfill the limit values of the standard (Figure 103).



Figure 103. *The limit values of the standard*



**ANNUAL INSPECTION / ANNUAL SERVICING PROCEDURES**

SERVICING PERFORMED BY / DATE:

NEXT SERVICING:

PRODUCT SERIAL

NUMBER:

		PROCEDURE	OK	NEEDS REPAIR
VISUAL INSPECTION:	BED SURFACE BOARD	A		
	SUPPORT STRUCTURES OF BED SURFACE BOARDS	A		
	UPPER FRAME STRUCTURES	A		
	LOWER FRAME STRUCTURES	A		
	FASTENING POINTS OF ACCESSORIES	A		
	SLEEVE OF LIFT SUPPORT STAND	A		
	CONTROL UNIT	B,C		
	MOTOR CABLES	B		
	FASTENING OF CABLES	B,C		
	POWER CABLE	B,C		
SERVICING AND INSPECTION:	MOUNTING OF MOTORS	C		
	CHECK TIGHTNESS OF BOLTS	C		
	JOINTS OF BED SURFACE MECHANISM	C,D,I		
	JOINTS OF LIFTING MECHANISM	C,D,I		
	CLEANING / WASHING STRUCTURES	IF NEEDED		
OPERATIONAL TESTING AND INSPECTION:	MOTORS	B,E,X		
	HAND-HELD CONTROL	B,E		
	NURSE'S PANEL (accessory)	B,E		
	BRAKES	F		
	OPERATION OF ALIGNING WHEEL	F		
	WHEEL BEARINGS	F		
	TRENDELENBURG (hospital beds)	G		
	RAILS	H,I		
	BATTERY CHARGING (accessory)	J		
	ACCESSORIES	A,C,E		

A) CHECK FOR POSSIBLE DAMAGE, BREACH, DEFORMATION, UNUSUAL TRACES OF WEAR

B) CHECK THE CONDITION OF THE BED'S ELECTRICAL EQUIPMENT AND CABLING; BREACHES, ATTACHMENT OF CABLES AND DEHYDRATORS, CONDITION OF PLUG, TRACES OF WEAR AND RUBBING OF CABLES

C) CHECK THAT THE LOCKING RINGS AND HOODS OF THE PINS ARE IN PLACE, CHECK THE TIGHTNESS OF ALL SCREW CONNECTIONS, FASTENING OF COMPONENTS AND MECHANISMS GENERALLY

D) LUBRICATE THE JOINTS, BEARINGS AND SLIDE SURFACES OF THE BED SURFACE MECHANISMS, AND JOINTS OF THE LIFTING MECHANISM, LUBRICATE THE BEARINGS OF THE ROCKER PIPES OF THE LOWER FRAME, REACTION ROD JOINTS, BRAKE LEVER JOINTS

E) OPERATIONAL TESTING, STOPPING AT EXTREME POSITIONS, ALSO WITH LOAD, TESTING THE OPERATION OF HAND-HELD CONTROL AND NURSE'S PANEL

F) CHECKING THAT ALL BRAKES HOLD, ALIGNING WHEEL LOCKS IN TRANSPORTATION POSITION, GENERAL CONDITION OF WHEEL BEARINGS, OPERATION OF BRAKE PEDAL

G) CHECK THE OPERATION OF ADJUSTMENT, CONDITION AND FIRMNESS OF GAS SPRINGS

H) CHECK OPERATION, LOCKING IN UPPER POSITION, SPACING OF LOWER RAILS, LUBRICATE LOCKS, SLIDE COMPONENTS, JOINTS, CHECK CONDITION IN GENERAL, IF NEEDED; BREACHES, FRACTURES, FASTENING

I) SUITABLE LUBRICATION GREASE IS E.G. WURTH HS 2000 SYNTHETIC SPRAY PETROLIUM JELLY OR EQUIVALENT

J) CHECK THE CHARGE CAPACITY OF BATTERIES, REPLACE BATTERIES IN BATTERY-OPERATED SYSTEMS AT LEAST EVERY TWO YEARS

X) WHEN CHECKING THE CONDITION OF MOTORS, PAY SPECIAL ATTENTION TO THE FOLLOWING AND TAKE SPECIAL CARE WHEN DOING SO

- IF THE BED HAS BEEN UNDER CONDIREABLE LOAD I.E. CONTINUOUS LOAD = SWL

- IF THE NUMBER OF LIFTING OPERATIONS EXCEEDS 3000 PER YEAR

WHEN TESTING THE OPERATION OF MOTORS, LISTEN FOR

EXCEPTIONAL NOISES IN MOTORS OR GEARS, REPLACE OR SERVICE THE MOTORS IF NEEDED

## 9.3 Battery maintenance procedures

The maintenance procedures of the hospital bed battery are performed by the bed operator. The AG7 battery used in the hospital bed is service-free, but taking care of the following points greatly impacts its life cycle:

- After long-term storage, the battery may require several charging and discharging cycles to reach peak performance.
- Several operation and control systems are using small quantities of electrical current even when the systems are not being used. This may result in complete discharging of the battery, which may damage the battery or disable it in some cases.
- In a bed equipped with a battery, the battery will discharge completely in a couple of days if the bed is not plugged in.
- If a bed with a battery is stored, the battery must be disconnected from the bed's electrical system for storage. If a bed with a battery is stored for longer than 6 months, the battery must be fully charged before storage. The battery must also be charged every 6 months during storage.
- The battery can only be removed and replaced by service personnel authorized by Lojer (vocational upper secondary qualification in machinery and metal sector or equivalent and valid SFS 6002 electric work safety training) or service personnel otherwise qualified to service medical equipment.

Remember, when managing the maintenance procedures, that the expected life cycle of the battery is approximately 1000 chargings.

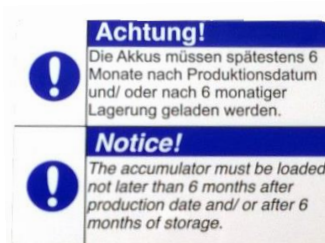

Figure 104. *Warning label on the battery*

## 10 Troubleshooting

Symptom	Fault	Procedure
One of the motors does not function.	The cable of hand-held control or motor is unplugged.	Check the attachment and condition of cables.
	Defective hand-held control.	Check the operation of the hand-held control by trying out an equivalent, functioning hand-held control on the hospital bed. Replace with a functioning hand-held control if needed.
	Defective motor.	Contact the service personnel.
	Defective relay card of the control unit.	Contact the service personnel.
	Motor's safety limit triggered.	Contact the service personnel.
None of the motors functions.	Defective hand-held control.	Check the function of the hand-held control as described above.
	No mains voltage.	Check that the power cable is plugged in.
	Defective power cable.	Check the condition of the cable and contact the service personnel if needed.
	Defective thermal relay of the transformer	Contact the service personnel.
	Defective hand-held control fuse.	Contact the service personnel.
	Defective relay card fuse	Contact the service personnel.
	Defective power cable fuses.	Contact the service personnel.

Symptom	Fault	Procedure
	The intermittent operation rule has not been followed and the thermal shield of the control unit has been triggered.	Allow the control unit to cool for 15 min. Do not use the functions of the bed during the cooling period.

To replace the motor, hand-held control or control unit and to place spare part orders, please contact Lojer service (see *Chapter 13 Contact information*). Have the following information readily at hand before contacting us:

- Product name and model
- Serial number
- Year of purchase
- Detailed description of the problem.

The product name, model, serial number and manufacturing date are given in the type plate located in the crossbar of the lower frame at the front end of the hospital bed (see Figure 106 *Type plate information*).

More detailed service instructions are given in a separate service instruction (see *Chapter 14 References*).

# 11 Specifications

Weight without equipment	108-110kg
Length (A)	215cm
Width (B)	82cm / 92cm
Bed surface height (C)	30 - 82cm (depending on model)
Backrest angle (D)	0-70°
Thigh rest angle (E)	0-30°
Leg rest angle (F)	0-18°
Width with rails (G)	89.5 / 99.5cm
Length of lower frame (H)	131cm
Push handle height (I)	39.5cm
Trendelenburg position	0-12°
Reverse Trendelenburg position	0-20°
Noise	52 dB (A)
Transportation temperature	-20 - + 50 °C, humidity 30-75 %
Storage temperature	-20 - + 50 °C, humidity 30-75 %
Operating temperature	+10 - + 40 °C, humidity 30-75 %
Air pressure	800hPa – 1060hPa(<2000m)

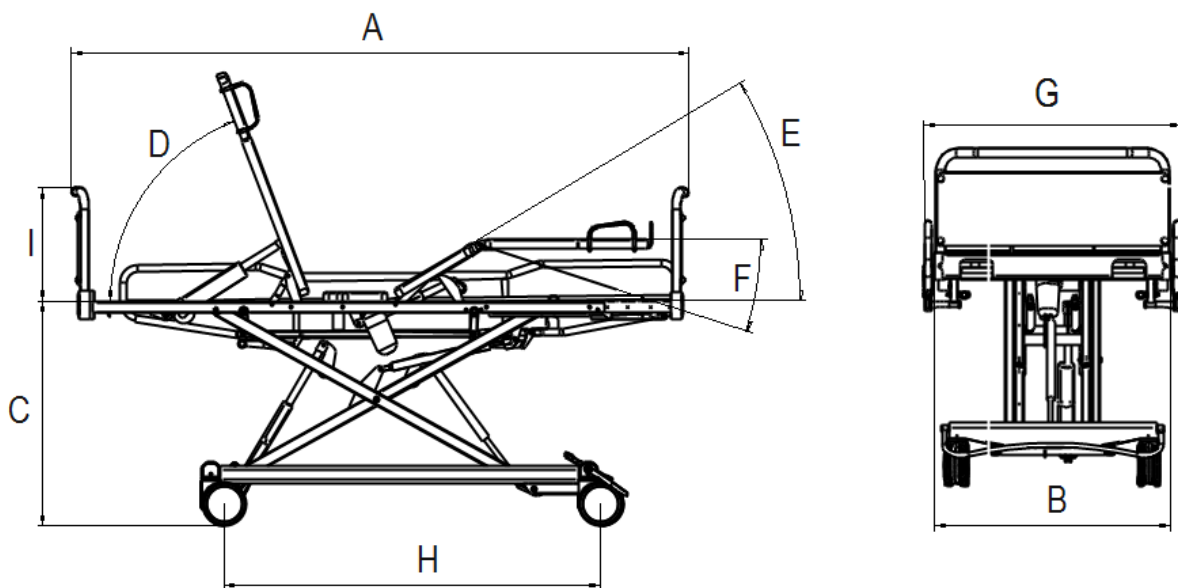

Maximum load SWL  
(see p. 8 Figure 3)

SWL	260kg models TK, S, ICU E / 340kg models ICU
Weight of patient	195kg models TK, S, ICU E / 250kg models ICU
Accessories	45kg models TK, S, ICU E / 70kg models ICU
Bed linen	20Kg models TK, S, ICU E and ICU

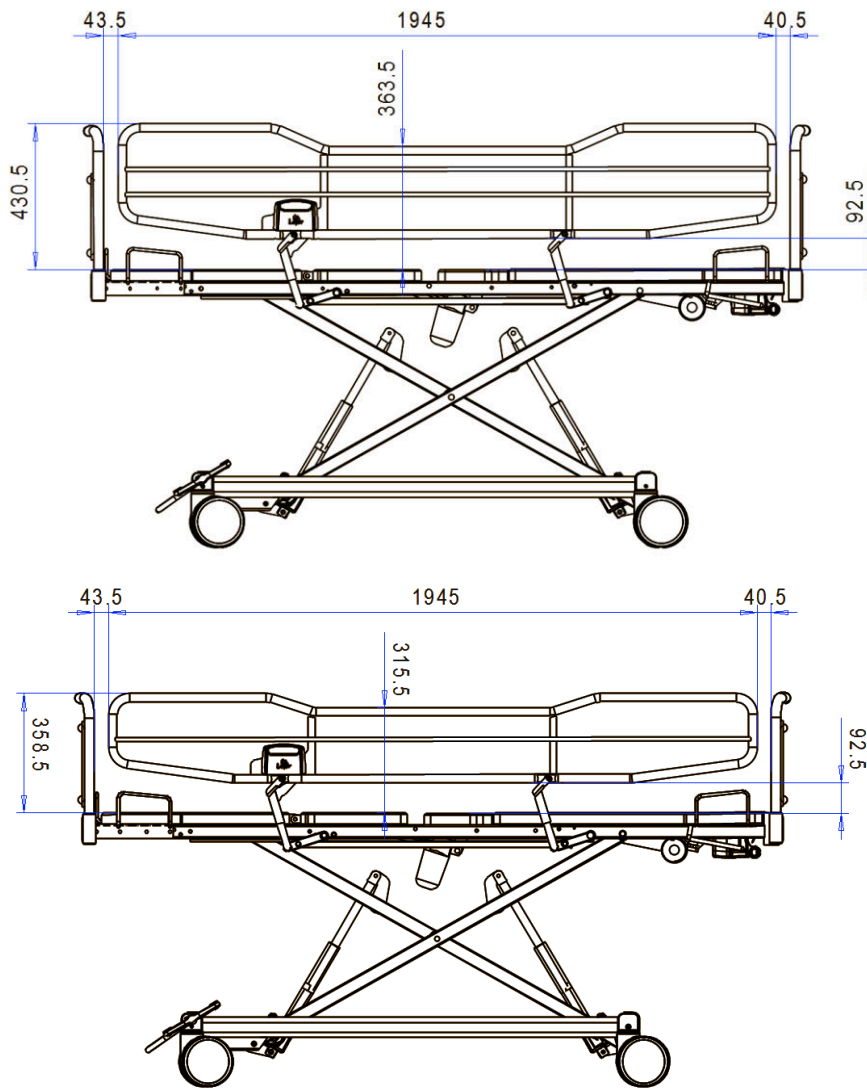

Figure 105. Rail dimensions

<b>Weight of accessories</b>	
Accessory	Weight
Long rails (pair)	15.8 kg
High rails (pair)	18.6 kg
End 80cm / 90cm	3.6 / 3.9 kg
High end 80cm /90cm	3.7 / 4 kg
Lift support	5.7 kg
Quick mounting frame (incl. 2 pcs)	3.6 kg
Get-up support (excl. quick mounting frame)	2.4 kg
Dining tray 80cm / 90cm	5 / 5.5 kg
Nurse's control board	0.7 kg
Nurse's locking board	0.3 kg
Display table	5.7 kg
Bedding aid	2.2 kg
Bed surface extension 80cm / 90cm (models S)	4.4 /5 kg
Trendelenburg extension handle	1 kg
Urine bag stand	0.1 kg
Fifth aligning wheel	3.8 kg
Battery	1.5 kg
Hand-held control stand	1.1 kg
Crutch and cane rack	0.6 kg
Cushioned rail guard	1.6 kg

## 11.1 Type plate information

Operating voltage	100-240V ~ 50/60Hz
Enclosure class	IPX 4
Intermittent operation	2 min. ON / 18 min. OFF
Power input	900 VA
Electrical protection class	Class I



Type B Applied Part (see Figure 110 p. 70)

CE

The product fulfills the requirements of directive 93/42/EEC and EN 60601-2-52: 2010

Internal electrical system (accessory)

1 x 24VDC, 1.22Ah lead gel battery



Figure 106. Type plate (Note! image indicative only) and its location on the bed

**IMPORTANT!** Wiring diagrams, component lists, specifications, calibration instructions and other product information which helps the service personnel to repair the components that require their attention are available at the manufacturer and provided on request.

**IMPORTANT!** The hospital bed circuits can be isolated from both poles of the mains voltage at the same time by unplugging the bed's power cable from the wall socket.



## 11.2 Relevant standards

The Lojer ScanAfia X hospital bed fulfills the requirements of directive 93/42/EEC (medical devices) and its current amendments.

The following unified standards have been used in the design and testing of the bed collection:

- EN 60601-2-52:2010
- EN 60601-1:2006

## 11.3 The bed's applied parts

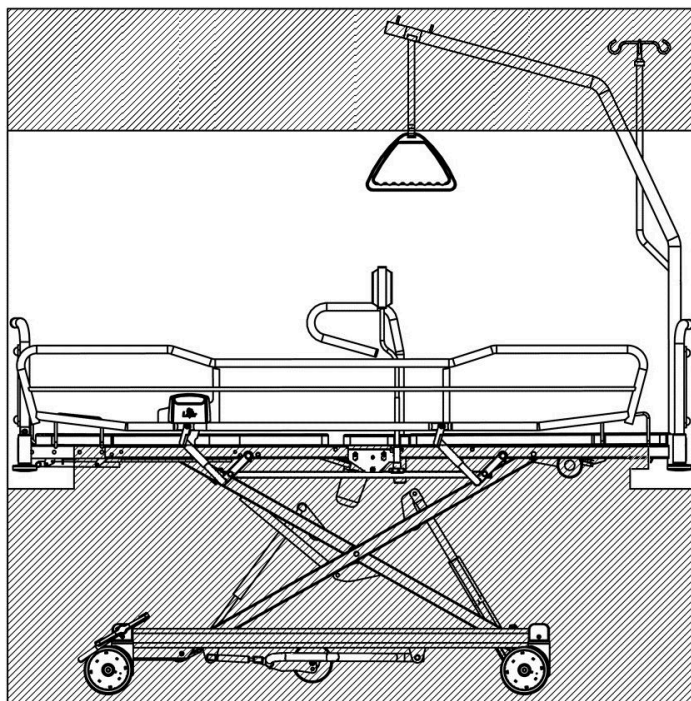

White, non-checked areas in the images are the bed's applied parts

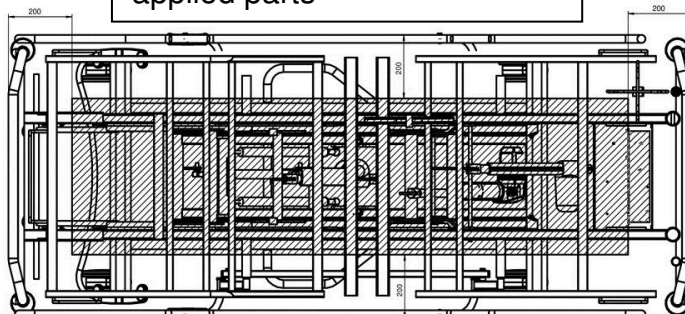

Figure 107. Type B Applied Parts

## 12 Recycling

A large part of the materials used in the device can be recycled. When the device can no longer be used, it must be dismantled and recycled appropriately. Recycling must be performed by a specialized company and the components of the device must not be disposed of among unsorted landfill waste.

### Pre-processing and storage

If the device has a battery, it must be removed at the end of life (Note! Remove also the batteries of the hand-held control). Remove the oils from the hydraulic system and take them to the appropriate waste processing plant. The gas spring must be depressurized and its oils removed before the metal is recycled.

### Demolition

The materials must be sorted before recycling:

- **SCRAP METAL:** frame, screws, nails, hinges, springs etc.
- **ENERGY WASTE (combustible waste):** solid wood and other wood-based materials, chipboard etc.
- **SER (electrical and electronic waste):** hand-held control, all cables, motors etc.
- **MISCELLANEOUS WASTE:** plastic components (wheels), upholstery and other components, in which the materials cannot be separated.
- Pre-processed and sorted materials are taken to the appropriate collection points. Always follow regional instructions and those posted at the collection points. Recycling reduces considerably the waste in landfills and the soil.

## 13 Contact information

### **Manufactured by:**

Lojer Oy

Putajantie 42

38210 Sastamala

Tel. 010 830 6700

Fax: 010 830 6702

Email: [firstname.lastname@lojer.com](mailto:firstname.lastname@lojer.com)

[www.lojer.com](http://www.lojer.com)

### **Service**

Tel. 010 830 6750, 010 830 6760

Email: [service@lojer.com](mailto:service@lojer.com)

[www.lojer.com/huolto](http://www.lojer.com/huolto)

### **Sales**

Tel. 010 830 6700

Email: [firstname.lastname@lojer.com](mailto:firstname.lastname@lojer.com)

## 14 References

*ScanAfia X beds Service instructions*

## ScanAfia X Quick guide

### NURSE CONTROL PANEL:

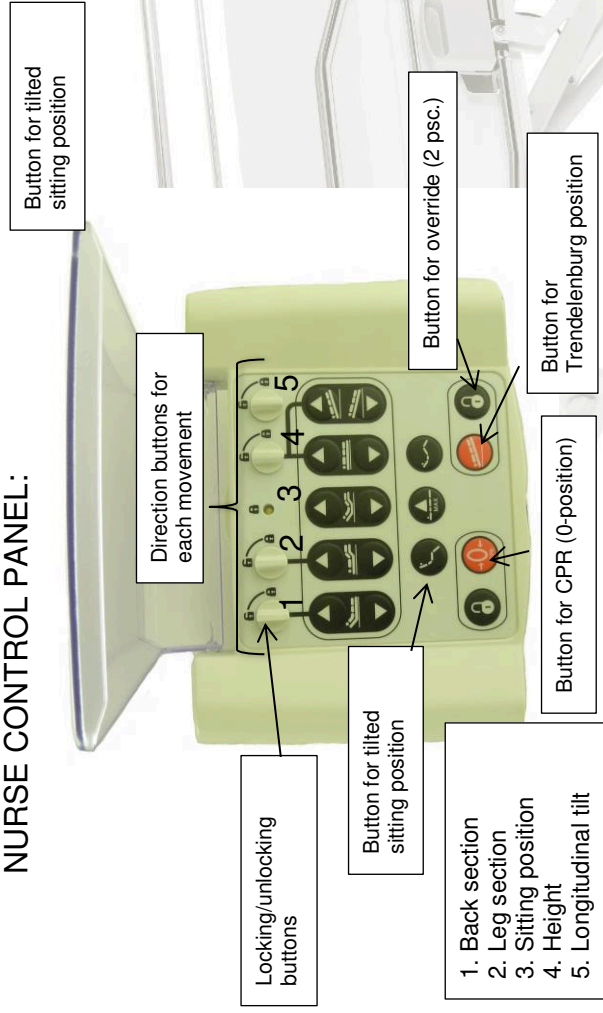

Familiarize yourself with the instructions for use.  
Familiarize yourself with the controls and the device.



Continuous light during movement. Blinking light: charging

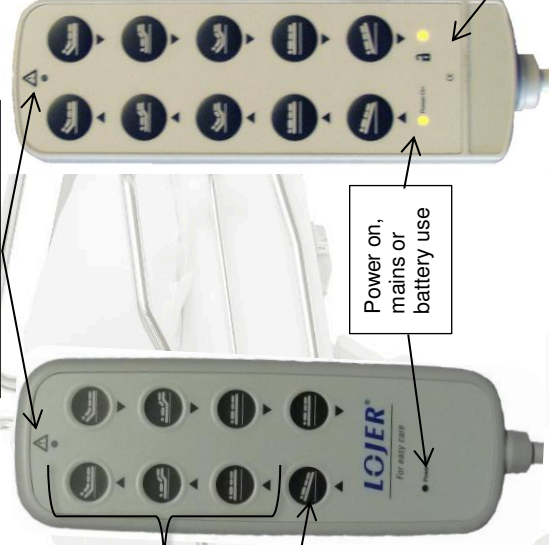

Activation of the lockable hand control  
Use the magnetic key to sweep over the bottom section of the hand control. The light turns green. Functions allowed for patient are in use. Sweep again and the light turns orange. Now nurse mode is on and all functions work. When the light is off, the control is locked and none of the functions work. The control will be locked after 40 s if not used in nurse mode.

Activate the hand control by sweeping the magnetic key over this area.

Hand control/Nurse control panel: Press the direction button of desired movement to adjust the bed. Movements can be locked from the nurse control panel. By turning the locking button(s), all movements are locked/unlocked. When needed the bed can be driven despite the locking by pressing simultaneously buttons for override and desired movement. The hand control which is locked with magnetic key, has to be activated always when the mains or battery power supply has been interrupted or when the Trendelenburg position is used.



IV-pole and lifting pole can be installed on the head or leg end of the bed. Make sure that the pole locks in place.



Make sure that the side rail locks in place when it is lifted up. To unlock the side rail, lift the lever and lower the side rail.



Lock/unlock the bed end in place with thumbscrew.



Manual trendelenburg (option)  
Pull both handles and tilt the bed. Pay attention when using this function. Remember to return the bed to horizontal position.

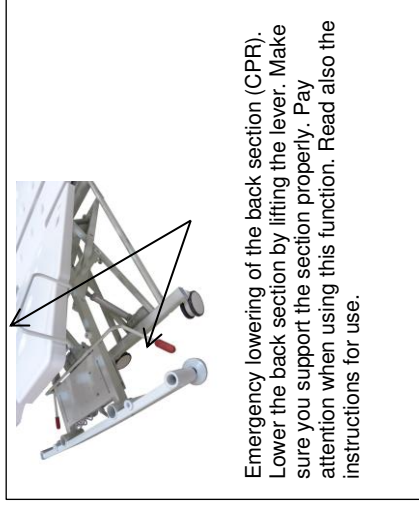

Emergency lowering of the back section (CPR). Lower the back section by lifting the lever. Make sure you support the section properly. Pay attention when using this function. Read also the instructions for use.

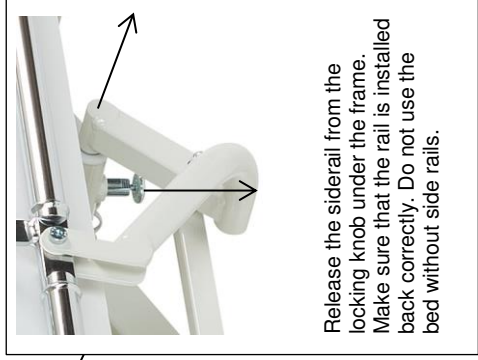

Release the siderail from the locking knob under the frame. Make sure that the rail is installed back correctly. Do not use the bed without side rails.

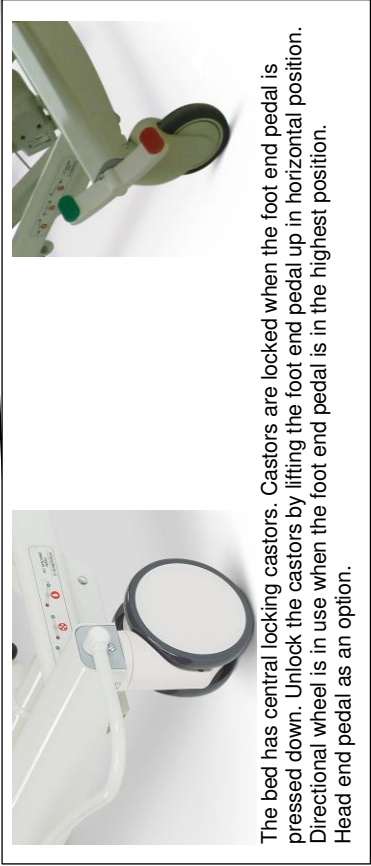
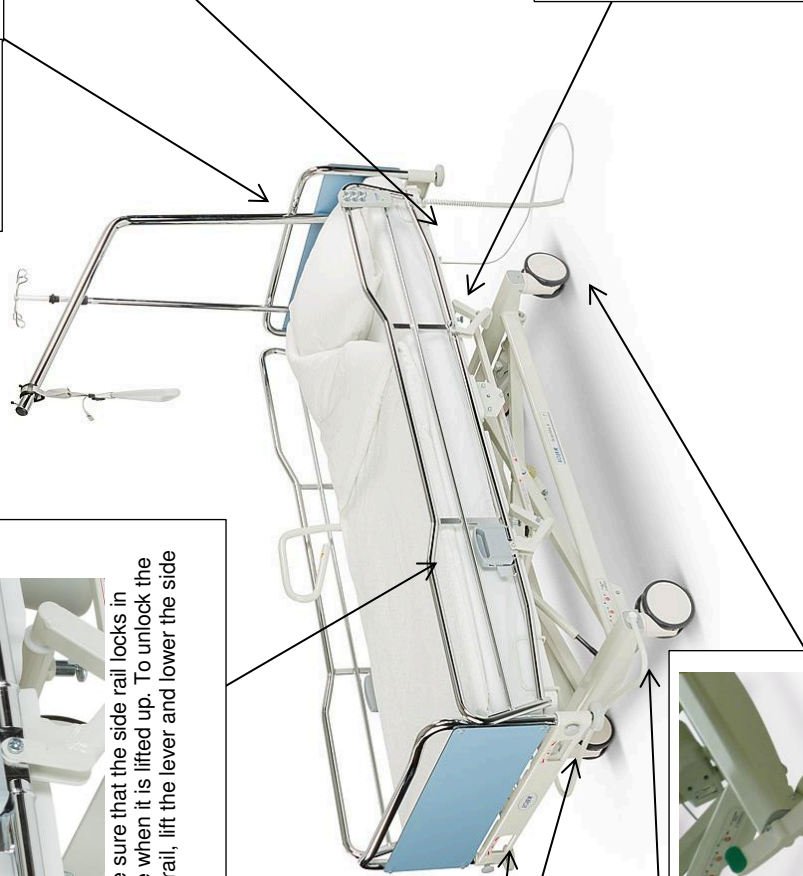

The bed has central locking castors. Castors are locked when the foot end pedal is pressed down. Unlock the castors by lifting the foot end pedal up in horizontal position. Directional wheel is in use when the foot end pedal is in the highest position. Head end pedal as an option.

**Lojer Oy**  
Putajantie 42, 38210 Sastamala, Finland  
info@lojer.com, service@lojer.com





==== [www.sport-tec.de](http://www.sport-tec.de) ====

**Sport-Tec GmbH**  
**Physio & Fitness**  
Lemberger Str. 255  
D-66955 Pirmasens

**Tel.:** +49 (0) 6331 1480-0  
**Fax:** +49 (0) 6331 1480-220  
**E-Mail:** [info@sport-tec.de](mailto:info@sport-tec.de)  
**Web:** [www.sport-tec.de](http://www.sport-tec.de)

